

Transportation Infrastructure Investment and Economic Integration: A Case of Vietnam Economy

A thesis submitted in partial fulfillment for the
degree of Doctor of Engineering

in the

Department of Urban Management

Graduate School of Engineering

Kyoto University

August 2011

Vu Trung Dien

Acknowledgements

I would like to express my deep and respectful gratitude to my supervisors, Professor Kiyoshi Kobayashi and Associate Professor Kakuya Matsushima, for their continuous support and guidance throughout three years of my PhD. Professor Kobayashi was always there for a meeting to discuss the ideas, to proofread my papers and to return chapter drafts with insightful comments. Associate Professor Matsushima is always encouraging and very supportive. Without both of my supervisors, it would have been impossible to complete this thesis. Special thanks are extended to another member of my research committee, Professor Norio Okada for providing me with valuable suggestions and discussion.

I am also very grateful to Assistant Professor Masamitsu Onishi, Assistant Professor Mamoru Yoshida the internal and external examiners of my viva examination for their constructive comments and suggestions to refine the thesis.

My warm thanks are due to all secretaries and staff in the Laboratory of Planning and Management Systems, Department of Urban Management, Graduate School of Engineering, Kyoto University for their kind assistance. I would like to take this opportunity to express my gratitude to the school of Global Centre of Excellency for financial supports, for conference attendance and internship, field trips.

My life in Japan would have been very boring without the daily accompany of other students of the laboratory, especially my international student buddies: Mr. Hisashi Mori, Dr. Hayeong Jong, Dr. Lei Shi, Dr. Xu Daming, Dr. Christakis Mina, with whom I enjoyed numerous discussions on all kinds of issues, from CGE models to those for a nation's culture. My life in Japan has experienced many wonderful rides with my Vietnamese friends, especially the co-members of Katsura Knights musical band: Huybau, NamCC, ThangRau, Hoangtroc, Hungkep, Huybeo and Vude.

Special thanks are given to my colleges in the laboratory of Professor Kobayashi.

Encouragement and support, of course, also came from our parents Mr. Vu Trung Dien and Mrs. Nguyen Thi Nga, whom I dearly love. My academic pursuit would have been impossible if my beloved wife, Thai Hoa, had not performed so double outstandingly in taking care of our family and doing her PhD program in Kyoto University. And if I have done well in anything, it is partially because of the untold encouragement of our children brave knight, Trung Son (Tomek) and lovely angel Thai Uyen (Hazuki-chan).

Finally, I shall not forget that my research is supported financially by the Yoshida Scholarship Foundation.

Executive Summary

The economist's researches have paid great attention on the linkages between transportation infrastructure improvements and economic performance and the relative strength of these links. However, the debating over the ways how to measure the effects of infrastructure transportation improvements on economy and how the two are linked are still rising nowadays. The connection between infrastructure transportation investment and economy has broader ramifications that go beyond basic purpose in transporting commodities and moving of people from one place to another. No doubt that the transportation infrastructure plays a center role and essential operation in a market economy; the needs to be studied the ways how the efficient transportation networks make improvement of productivity of one economy.

In addition, in the all modern economies, one of the most important is the ability to transport commodities and human. The mobility affects the economy differently depending upon the purpose of each trip. The modern economies are dependent upon transportation in transport people and goods to and from other economies. Access to other economies enables trade and facilitates the specialization of labor and capital, leading to greater productivity and higher wages. Without such access, the improvement of productivity would not occur, and lower average productivity and lower wages happened as results.

There are three broad methods have been employed to research about these linkages include macroeconomic, microeconomic research and general equilibrium analysis. In which general equilibrium approaches focus on measuring the benefits of transportation improvements gained from regional specialization and technological changes. The use of this method to analyze linkages between transportation improvements and the economy is still relatively new.

In ASEAN Economic Community, an efficient and integrated transport system is imperative for member countries to improve their economic competitiveness and facilitate their integration with the global economy. An integrated transport system is expected to significantly contribute to the establishment of the ASEAN as a single market and production base characterized by the free movement of goods, services, investment, labor and open flow of capital.

Recently Computable General Equilibrium (CGE) model analyses are becoming more essential tool and more popular for estimating the effect of transportation infrastructure investments on the economy, to fill up the requirement of the differentiation among regions. Almost CGE applications up to now only taken the impacts of goods transport

costs into consideration. Few studies extended and paid attention on welfare effects that are due to the time and costs savings in passenger transport. So far many researches are already made for assessing the important of infrastructure investments as well as costs and benefits of individual projects, however, not many study is about the spatial distribution of the benefits. There are numerous methods using for this purpose.

Aschauer [1] and Pfahler [2] measured benefits by estimating rates of return on infrastructure investment in a production function approach, using cross section, time series, in which the regional distribution of effects is concerned. When accessibility changes it may raise regional affects in different way, depending on the pattern of interregional flows. Spiekermann [3] approaching method is to measure the impact of transport cost reductions by accessibility indicator showing how a region's generalized cost of reaching its markets and of traveling to a hypothetical set of destinations is affected by the costs reductions. Next, accessibility changes are then related to regional economic indicators like GDP per capita or real growth of GDP. Passenger transport systems are the foundation of economy so that households and private firms can utilize them in consumption and production activities.

The multiregional CGE models have been paid attention in order to assess the regional policies changes include infrastructure transportation investments. The pioneering studies by Dixon (1982) developed a top-down model that decomposes national variables into regional. Liew *et al.*, [4], developed static Multiregional Variable Input-Output (MRVIO) model considers price differentials due to transportation within a multiregional I-O model. Recent years, a multiregional CGE has been raised in which transport costs explicitly appear as firm's expenditures for transport and other kinds of business travel and as households' costs of private passenger travel.

CGE models with a spatial dimension have been applied to transportation infrastructure investments by several authors Brocker [5], Ueda *et al.*, [6], and Venable [7]. However, there have limitations in these models, for instant, they considered to trade costs and regardless the costs of passenger travel or inverse, they consider costs of business trip but disregard transportation cost for commodities.

During 2000s, Horridge *et al.* [8] developed a bottom-up model named TERM (The Enormous Regional Model) which used to assess the regional impacts of an economic event in a country, and the database from non-survey regional I-O tables and an inter-regional trade matrix. The original version of TERM is a comparative static model. It shows, for a single year, the differences produced in the regional economies by changes in taxes, technology, tariffs and other exogenous variables. Various versions of TERM

have been prepared for several countries including Brazil, Finland, China, Indonesia, South Africa, Poland, and Japan.

More recently, Sharina *et al.* [9] have discussed the current issue in globalization and optimum production allocation of heterogeneous firms. They proposed a two countries general equilibrium model that integrates the comparative advantages theory and new economic geography theory. The model mainly applied in heterogeneous firms that consider the costs associated with the different production technologies between firms and transportation cost between two countries.

The aim of this thesis is to make a comprehensive assessment of transport infrastructure improvements on the economy. This research introduces a multiregional CGE model for Vietnam. It deals with the effects of infrastructure transportation investment in commodities transportation cost of interregional trade and households' welfare effects due to the time and cost saving in passenger transport. The passenger transport includes business trips and individual resident travel.

The research includes the following purposes: (i) to develop a multi-regional CGE model that explicitly considers the transportation sector, (ii) explore the impacts of reducing transport costs from transportation infrastructure investment among Vietnamese regions, and (iii) estimating the effects on the change of commodity flow volume and passenger travel cost. The data bases of the model are aggregated from interregional Input-Output table 2005 for Vietnam and the Input-Output table 2005 for Vietnam and other sources such as derived from GTAP data base version 7.

The thesis is organized as follows. **Chapter 2**, general information background about global economic integration, the economic effects of transportation infrastructure investment and economic assessment are provided. This chapter briefly reviews the regionalization in European, American and East Asia countries. The current researches on the effects of transportation infrastructure investment from both passenger flows and freight transport on the regional economic integration are provided. Chapter 2 also provides information on development of CGE modeling and its applications in term of transportation affect to the economy in various regions and countries including America, European, Asian and Vietnam specifically.

Chapter 3 provides a brief overview, background on current status and trends of transportation infrastructure investment in Vietnam as well as the transport policy in the future. The paper summarizes the results of the effectiveness from transport investment projects over the country in recent years. Also describes the current status of Vietnam's transport policies implementation as well as methodologies for measuring the effects of the transportation infrastructure investments on the country's economy. The final part

of this chapter offers conclusions regarding the status of Vietnam's transport sector and policies and recommendations regarding modeling analysis for estimating the economics effects of transportation investment in the country.

Chapter 4 describes about data base preparation for the research. The characteristics and development of Vietnamese economic data are mentioned. The chapter mainly focuses on input-output table data of Vietnam after overview input-output systems in general. To produce output, sectors require each other's inputs. The economy is classified by sectors, the sectors may have a variety of commodities as inputs and their outputs are not mixed. Each sector is identified with the commodity that it produces. Chapter 4 also provides the development of Input-Output analysis for Vietnamese economy. One of the novelties in this thesis which is the establishment of transportation data for Vietnam also provided in this chapter.

Chapter 5 develops a multi-regional, multi-sector CGE model that concentrates in particular on case of Vietnam. The model descriptions particular emphasis on the theoretical structure and the equations linkages used in the CGE framework. The multi-regional CGE model for single country's economy developed which is used to study the regional economic effects of transportation infrastructure investment. We consider a country's economy with number of sectors, the country divided into various regions. Transportation infrastructure investment makes changes to productivity of the firm's commodity. Applying the CGE model, we explore the impacts of reducing transport costs from transportation infrastructure investment among regions, estimating the effects on the change of commodity flow volume and welfare effect due to both commodity freight transport and passenger flows. The important novelty in the model is the incorporate time resources of human business trip and commodity transport into the production function. The data bases for empirical study of the model are aggregated from interregional Input-Output table 2005, Input-Output Table 2005 for Vietnam and derived data from GTAP data base version 7 which is made in previous chapter.

Chapter 6 focuses mainly simulations of multiregional CGE which developed in the previous chapter. This chapter divided into two parts. First, we make a simulation using Global Trade Analysis Project (GTAP) model to estimate the economic effects of international transportation improvement on Great Mekong Sub-region (GMS). The data used for the simulation derived from GTAP Data base version 7. Second, a preparation of data base for simulation of multiregional CGE model for Vietnam, calibrated to the 2005 interregional input-output which is published in 2009, production and household data, the model is to evaluate the efficiency and distributional effects of transportation improvement. The country's economy model has seen as a standard small open

price taking economy model, with CES nested demand, CES and Leontief production functions.

The GTAP-based model analyzed the effects of the international transportation projects on the GMS countries' economy. The results show that they will surely accelerate the development of Vietnam and the other GMS members by enhancing economic integration among them. The results indicate that the economic growth in Vietnam is particularly significant. More imports become available in Vietnam because the market price of imports decreases, both from other GMS members and from the rest of the world. This enhances production and consumption in the country.

In addition, the exports from Vietnam become more competitive in foreign markets due to the reductions in time and cost.

Finally, **Chapter 7** summarizes the final conclusions, compares the model results with other previous studies, discusses the role of transportation infrastructural improvement in the country economy and regional economic integration, points out the model's limitations and suggests extensions for future research.

Contents

Acknowledgements	iii
Executive Summary	v
List of Figures	xv
List of Tables	xvii
Abbreviations	xix
1 Introduction	1
1.1 General introduction	1
1.2 Problem Statement	2
1.3 Objectives of Research	5
1.4 Scope of Research	6
1.5 Expected Contribution	7
2 Literature Review	9
2.1 General introduction	9
2.2 Global Economics Integration	9
2.2.1 Overview	10
2.2.2 European and America	11
2.2.3 East Asian Regionalization	13
2.3 Transportation Infrastructure Investment	17
2.3.1 Background	17
2.3.2 Roles of Transportation Infrastructure	18
2.3.3 Freight Transport	19
2.3.4 Passenger Transport	21
2.4 CGE Modeling Analysis	22
2.4.1 Background	22
2.4.2 CGE Modeling in United States	25
2.4.3 CGEurope Modeling Development - IASON Project	25
2.4.4 Multi-Regional CGE model	26
2.4.5 CGE Models in Asian Countries	27
2.4.5.1 Japan Case	27
2.4.5.2 China Case	29

2.4.6	CGE Models Analysis in Vietnam	31
2.4.6.1	Input-Output Analysis	31
2.4.6.2	CGE Modeling Analysis	33
2.5	Conclusion	35
3	Transportation Infrastructure Investment and Policy in Vietnam	37
3.1	General introduction	37
3.2	Overview	37
3.3	Vietnam's Transport Sector	39
3.3.1	Key Drivers of Transport Sector	40
3.3.2	Current projection of transport investment	42
3.3.3	Efficiency of Transportation Investment in Vietnam	43
3.3.4	Availability of Vietnam's Transportation Data	45
3.3.5	Transportation Policy of Vietnam	46
3.4	Summary and Recommendations	46
4	Input-Output Table Analysis	47
4.1	General introduction	47
4.2	Vietnamese National Account	48
4.3	Vietnam Input-Output Table	48
4.3.1	Competitive Imports IO Table	49
4.3.2	Non-competitive Imports IO Table	50
4.3.3	Basic Principle of IO Table	52
4.3.3.1	Output	52
4.3.3.2	Data collection methodology	52
4.4	Interregional IO Table for Vietnam (IRIO)	53
4.4.1	Construction of IRIO	54
4.5	Transportation Satellite Accounts	57
4.5.1	Introduction	57
4.5.2	Transportation Data Availability	58
4.5.3	Objective of TSA	59
4.5.4	Relationship of TSA with National Accounts	61
4.5.4.1	The System of National Accounts	61
4.5.4.2	Relationship of the TSA to the IO table	61
4.5.4.3	Component of the TSA	63
4.5.5	TSA for Vietnam and IRIO	65
4.6	Summary and Recommendations	65
5	CGE Modeling with Freight Transport and Passenger Flows	69
5.1	General Introduction	69
5.2	CGE Modeling analysis and transport	69
5.3	A Multi-regional CGE Model	71
5.3.1	Introduction	71
5.3.2	Structure of the Model	72
5.3.2.1	Overview	72
5.3.2.2	Main Assumptions	73
5.3.2.3	Firms' behaviour	74

5.3.2.4	Households' behaviour	78
5.3.2.5	International Trade model	80
5.3.2.6	Equilibrium Conditions	82
5.3.3	Economic Effect Analysis	83
5.4	Dicussion and Conclusion	84
6	Simulation of A Multi-Regional CGE Model: A Case for Vietnam's Economy	85
6.1	General Introduction	85
6.2	A Simulation base on GTAP model	86
6.2.1	Overview	86
6.2.2	Method	88
6.2.3	Scenarios	89
6.2.4	Results	90
6.2.5	Discussion	93
6.3	A Simulation with Vietnam IRIO Data	94
6.3.1	Introduction	94
6.3.2	The Model	96
6.3.3	Structure and Specifications of the Model	96
6.3.3.1	Production	97
6.3.3.2	Household demand side	98
6.3.3.3	Transportation	99
6.3.3.4	International trade	99
6.3.4	Data	100
6.3.4.1	Primary input factor data	100
6.3.4.2	Elasticity data	100
6.3.5	Simulation	101
6.3.6	Benchmark Data, Parameters and Elasticities	101
7	Conclusions and Recommendation for Future Works	111
7.1	A Brief Summary	111
7.2	Conclusions	112
7.3	Recommendations for Future Works	112
A	Appendix A	115
	Bibliography	117

List of Figures

2.1	Transportation infrastructure and Economy	21
3.1	The increasing of transport demand in both freight and passenger transport	41
3.2	Volume of passengers' traffic in Vietnam, 1995-2008	42
3.3	The strategic transport networks in Vietnam.	43
3.4	The Enlargment of Transportation in Red Delta Region.	45
4.1	Framework of IRIO table for Vietnam. Note: subscripts (*) indicate that the value represented in original IRIO table	54
4.2	The spillover and feedback effects in the regions model of Vietnam	58
4.3	New IRIO table for Vietnam with commercial-transportation and self- transportation sectors	66
5.1	The assumptions of the model	73
5.2	Production technology.	75
5.3	The structure of household's utility function.	79
6.1	GMS economic corridors	87
6.2	Production technology.	99

List of Tables

2.1	Trends of per capita GDP in ASEAN and selected trading partner countries/regions	15
2.2	Keys ASEAN statistical factors 2009	16
2.3	Land Transport Indicators in ASEAN Countries	19
3.1	Volume of domestic freight and passenger transport, 1999-2004	39
3.2	Transport Sector Expenditure in Vietnam 1999-2002. <i>unit in billion VND</i>	40
3.3	GDP growth by sectors in Vietnam 2000-2008	40
3.4	Population growing in Vietnam and its distribution, 2000-2008	41
3.5	Investment Demand for Transport Infrastructure	44
4.1	Development of National Accounts and IO Compilation in Vietnam	49
4.2	Framework for competition-imports IO table.	49
4.3	Framework for non-competition imports IO table.	51
6.1	Regions Classification	89
6.2	Sector Classification	89
6.3	Conditions of transportation improvement in the scenario analysis	90
6.4	Real GDP changes in the GMS countries in the four Scenarios	91
6.5	Changes in interregional trade between GMS member and ROW in the three Scenarios	92
6.6	Estimated changes in output by industry in the Scenario 1	93
6.7	Estimated changes in output by industry in the Scenario 2	94
6.8	Estimated changes in output by industry in the Scenario 3	95
6.9	Sectoral Aggregation Used in the Multi-regional CGE model	98
6.10	Definition of set	101
6.11	Activity level	101
6.12	Price index	101
6.13	Elasticity of Substitution	102
6.14	Firm's behavior	102
6.15	Classification of regions aggregated from the 63 provinces in 2005 IO table	103
6.16	Classification of sectors and goods	104
6.17	Substitution parameter between primary factors in the CES value-added nest of the nested production structure of the sector in all region	105
6.18	Production side elasticity of substitution in the Model	106
6.19	Population and Labor Structure	107
6.20	Labor and Wage rate	107
6.21	Consumption side Elasticities of Substitution Used in the Model	107
6.22	Armington Elasticities	108

6.23	Volume of passenger transport	108
6.24	Volume of Freight transport	109

Abbreviations

Acronym	What (it) stands for
APEC	Asia-Pacific Economic Cooperation organization
ASEAN	Association of Southeast Asian Nations
CGE	Computable General Equilibrium
CES	Constant Elasticity of Substitution
EAEC	East Asian Economic Caucus
EAFTA	East Asian Free Trade Area Agreement
GDP	Gross Domestic Product
GSO	General Statistics Office
GTAP	Global Trade Analysis Project
IRIO	InterRegional Input-Output
NAFTA	North America Free Trade Area
MPS	Material Product System
SAM	Social Accounting Matrix
SNA	System of National Accounts
TSA	Transportation Satellite Accounts
US-CAFTA	US-Central American Free Trade Agreement

Chapter 1

Introduction

1.1 General introduction

Transportation infrastructure plays an important role in regional and global economic integration, the linkage between the two has to play a significant role in the transport network plans and the relationship between the two has always been a concentrate of economists. However, the relationship between infrastructure transportation investment and economic development has been the subject of investigation for quite little time. Until 1980s, there has come with several studying the relationship between transport infrastructure and economic development. Aschauer [1] explained the lowered productivity of 1970s United States of American with transport infrastructure because of the decreasing public investment and productivity had dropped. Through Aschauer's neo-classical growth model, which econometrically analyzed the infrastructure decrease and the subsequent productivity falling, he concluded that transport infrastructure had an important role.

The role of transport infrastructural in economic development is also usually discussed in relation to its contribution to the development of domestic trade. Globalization has changed this perception. The ability of a country, and particularly the more isolated communities within a country, to participate in trade depends on the quality of transport and communication infrastructure that allows them access to the world trading system. Once liberalization of trade can open new markets for developing countries, then efficient transportation infrastructural systems will be needed to connect domestic producers with these markets. Appropriate transport costs, timely delivery and the quality of services provided are essential elements in calculating and assessing the competitiveness of products for global markets. In recent years, many countries have undergone changes

in trade and economic integration policy. Policy shifts in these aspects may have very different effects across regions due to regional differences in economic structure and the existence of high transportation and communications cost. As a result, market links across are weak, the national economy may be better seen as a collection of imperfectly linked regional economies.

Economic integration between countries and regions is easier within geographically close countries because the lower of transportation costs. The geographical proximity between neighbors countries or regions happens when exists good transportation infrastructure that connecting the countries or regions. In ASEAN countries and neighbors economies, the transportation networks that connecting including highways and railways are inadequate. It difference in comparison with European Union and US. Hence, the need of transportation infrastructural investment to obtain the improvement in transportation network is needed in order to fully realize the economic effects of their geographical neighbors.

1.2 Problem Statement

Globalization and regionalism are the major trends of both today and future's global economy. The world economy becomes more integrated, the development of international trade together with greatly stimulated of transportation improvements are recognized in many regions. Global Economic Integration was fashionable again since 1990s not only in Americas but also in Europe as well as Asia. In America after years of resistance to the idea in North America and a string of past disappointments in South America, the countries of the region have now created or are negotiating preferential trading arrangements of a bewildering variety of forms and extents. One of the most convincing theoretical explanations for pursuing integration on a regional basis is the belief that transaction costs, and in particular transportation costs, may be lower regionally than globally.

Amjadi *et al.*, [10] considers some of these arguments and then examines a source of detailed data on transportation costs on trade between Americas countries such as Argentina, Brazil and Chile on the one hand and the USA on the other. It shows that it is quite difficult to explain American integration in terms of transportation costs and even suggests that the latter might gravitate towards recommending against further policy-led integration. The study has examined three models in which transportation costs interact with economic integration schemes. In one, costs with non-partners suggest a reason why integration may be economically efficient. In the second, the relative cost

of intra and extra-bloc trade determined with whom a country should integrate. In the third, intra-bloc transaction costs could cause integration to be harmful.

Economically considering, any change in policy has led to a number of consequences that fall into the category of either cost or benefit. Traditionally, any action is undertaken by an individual or firm comes from gaining benefit. And only first-order reactions to infrastructural investment have been taken into account. That is when obtained transportation infrastructure improvements, we firstly consider the benefits in travel time savings, reduced fuel costs, decreased accident rates, lower environmental impacts, and reduced cost of shipping. The cost reduction of shipping is a first step in a multi-phased series of benefits that occur as firms shift expenditures away from maintaining stock on hand and toward other more productive uses.

Recently, logistics has become one of the largest businesses in the world with firms in every sector doing at least some business with logistics providers. This lead to the growing need for immediacy to deliver lower inventory costs, the benefit from the reduction in logistics costs is more readily capitalized upon by logistics firms. These savings are passed on to producers who pass them on to consumers and reinvest in their own logistics needs. Furthermore, the carrying cost of maintaining production input stock on hand is reduced, as firms can better rely on the shipping system to deliver goods when needed.

The effects of transportation infrastructure improvements still much attractive works that economist seek to estimate. For example, from improvement of transportation infrastructure lead to immediate cost reductions to carriers and shippers, including gains to shippers from reduced transit times and increased reliability; reorganization-effect gains from improvements in logistics; gains from additional reorganization effects due to changes in product quality or changes in demand for products and output from broader access to suppliers and markets; or effects that are not considered as benefits according to the strict rules of benefit-cost analysis, but may still be of considerable interest to policy makers. These could include increases in regional employment, or growth rate of regional income.

A savings in travel time is usually the primary user benefit of a transportation infrastructure investment project; such savings typically constitute well over half of the total user benefits. Increase in transit services, variability in travel time may be reduced without a significant reduction in the mean travel time. Reductions in the variability of travel time also have become a major consideration in projects serving freight transportation.

The value of travel time savings, and of the reduced variability of travel time, can be thought of in terms of reduced opportunity costs. In other words, savings in time can

be used for activities other than traveling, allowing individuals and firms to be more productive or to have more time for recreational activities. For example, when a business reduces its delivery times as a benefit of a transportation improvement, it may become more competitive and gain a larger customer base. The saved time can then be used in production activities. Savings in travel time can also be valuable for commuters who gain additional time for work, household activities, and recreational activities as travel times to destinations are reduced.

Potential transportation infrastructure investment projects traditionally have been evaluated on the basis of a combination of engineering and economic criteria. Projects are generally selected according to how significantly they would improve such important performance measures as total travel time through a network and safety. In recent years, however, increased attention has been given to the effects of transportation projects on members of society other than users of the facility to be improved. The social and economic effects of transportation projects should be fully considered because (i) these effects can be substantial and (ii) they often are important to the quality of people's lives.

So far, different studies on effects of transportation infrastructure investment on economy integration have been discussed in isolation. There are three classes of models that recently used.

The first one, as note in Roson and Vianelli [11], computable general equilibrium models, which is derive transportation flows from domestic and foreign trade. For example, e multi-regional model includes the transport cost of delivering commodity and services between producers and consumers. Transport cost changes lead to affects both the location and the levels of production and consumption, generating long term consequences for the entire economy.

The second one, Rohr and Williams [12], Williams and Lindberg [13] mentioned that spatial input-output models derives transportation flows from detailed spatial characteristics of existing transportation networks. Transportation network is regarded as a set of service point and links between them. Compare to CGE models, the distinguishing feathers of spatial input-output models are explicit transportation sectors as a transportation network and dynamic changes in transportation flows.

The third one is macroeconomic models with transportation incorporate transportation flows as given through the existing level of national transportation investment, cost of the use of transportation facilities. The models are expressed in a form of relationship between macroeconomic variables, using involving time lags which established by statistical analysis of empirical data, see Minford *et al.*, [14].

However, the two later models are quite time consuming because they require a large amount of spatial data then in they can only applied at regional levels. Hence, CGE model seems an appropriate analysis with given the nature of policy experiments and likelihood of far-reaching economy-wide implications, CGE is an appropriate tool to adopt.

In context of Vietnam, previous and current economics models developed for Vietnam do not have capturing and paying attention on transportation infrastructure improvement. Moreover, a multi-regional general equilibrium transport model analysis with Input-Output and Interregional Input-Output data based CGE model have never been attempted for Vietnam. The multi-regional CGE model in this study will basically deal with following issues: (i) transportation is consumption good of household and services of firms; (ii) transportation services produced by transportation sectors in the economy; (iii) firms use both self-transportation and commercial-transportation for production process and delivery good to consumers.

1.3 Objectives of Research

The main objective of this study is to use computable general equilibrium framework to identify and quantify the economic effects of transportation infrastructure investment. More precisely, the study intends to look at the effects of the reduction in commodity transportation cost and passenger travel time due to improvement of transportation infrastructure. They can be categorized into three concrete items as follows:

1. Development of Transportation Satellite Account base on Interregional Input-Output Table and Input-Output Table for Vietnam.
2. Developing theoretical multi-regional CGE model with focuses on the effect of transport infrastructure investment on the economy. Particularly, considerations are on building model for one small open economy country of Vietnam. A multi-regional CGE model with consideration of freight transport and passenger flows have been applied in order to estimate the effects of the economic impacts of transport policies. The model is developed for both freight transport and passenger flow improvement.
3. Demonstrate some theoretical of above multi-regional CGE model by conducting a simulation with data of Vietnam.

To achieve objective (1) we adopted transportation satellite accounts of Bureau of Transportation Statistics, US Department of Transportation [15] for estimating the size and role of transportation in the economy. This new accounting tool provides a way to measure both self-transportation and commercial-transportation services. The TSA reveal several important features concerning the relationship between transportation and the economy. A key concern addressed by the TSA is credibility of transport estimates. Since both self-transportation and commercial-transportation services are not identified as a separate activity in the Input-output table and IRIO table. These tables provide details estimation of intermediate inputs purchases by firms including commercial-transportation service sectors, and then we can use to prepare the TSA estimates. The objective of a TSA is to bring together the information by essentially re-organizing the national accounts and supplementing them with additional concepts and data, and thus develop relatively credible quantification of different aspects of transportation.

To achieve objective (2), in our model, we consider a country's economy with number of sectors and one explicit sector as transportation. The country divided into number of regions. We explore the impacts of reducing transport costs from transportation infrastructure investment among regions, estimating the effects on the change of commodity flow volume and welfare effect. The model, regional demands and supplies of commodities are determined through optimizing behavior of agents in competitive markets. Optimizing behavior also determines demands for labor, capital and intermediate goods. The mobility of production factors is a critical feature of every general equilibrium model. Capital can cross regional borders in response to capital- market conditions and the total capital stock of the economy is fixed. The capital is equally owned by households and each of them can receive an equal share in capital rent as a part of their income. Labor is assumed regionally immobile means the population of each region is exogenously fixed. The transportation system is used for inter-regional trade of commodities. To achieve objective (3) after developing the theoretical multi-regional CGE model and building transportation data from existing Interregional Input-Output Table and Input-Output data of Vietnam we focus on the change of transportation infrastructure due to self-transportation and commercial-transportation of the firms. The simulation reports the impact on welfare (EV) as well as trade relative trade flows.

1.4 Scope of Research

Scopes of the study are given as follows:

- Summarizing the current transportation investment policy of Vietnam. Existing models used to estimate the economic effects of transportation investment are discovered. Suggesting appropriate methodology for policy-maker in order to estimate the efficiency of transportation infrastructure investment policy for Vietnam's economy. This study is written in chapter 3.
- Aggregating Interregional Input-Output data as well as Input-Output data for and developing transportation satellite account as a new database for Vietnam. This study conducted in chapter 4.
- The scope of chapter 5 is to develop a multi-regional CGE model with focuses on the effect of transport infrastructure investment on the economy with consideration of freight transport and passenger flows have been applied in order to estimate the effects of the economic impacts of transport policies. An empirical study was conducted with data of Vietnam. This study is written in chapter 6.
- Conclusions and recommendations on data development, models and empirical studies are given at every last section of respective chapters.

Four main chapters linked through the definition and consideration of transportation data, developing of model as well as in the simulation with transportation data.

1.5 Expected Contribution

This thesis examines the topic of transportation infrastructure and economic integration using the multi-regional CGE model with Interregional Input-Output data. The analysis provides insight into the characteristics of the underlying transportation economic along with the effects of freight transport and passenger flows in term of freight volume and time resources, respectively, from the changes in the transportation infrastructure investment.

The novelty of this research is that it identifies new transportation satellite accounts for the country's economy, and to endogenous, incorporates travel time with keeping consistency SNA by defining wage rate corresponding to the time, explicitly consider transport sector by keeping consistency of TSA with SNA.

It is very positively that, after completing the research, the knowledge of this research will contribute to some extent as follows:

-
- A transportation data obtained through transportation satellite accounts in chapter 4 is hope to bring in transport economic contributions for researchers, particular for Vietnam and ASEAN member countries.
 - A multi-regional CGE model in chapter 5 with incorporates travel time is hoped to bring in innovative academic contributions, particularly about the estimation the effects of transportation policy change on freight transport and passenger travel time.
 - The empirical studies might be extended to cover not only in Vietnam but also for developing countries in ASEAN economic region.

Chapter 2

Literature Review

2.1 General introduction

This chapter reviews the trends of global economics integration in recent decades in the world and the impacts of transportation infrastructure development on the economy. It still increasing debates on the ways that how to estimate the linkages among the transportation and the economic integration. Many studies had been developed and most related to computable general equilibrium modeling analysis (CGE) which shown its high potential for the latter investigation in this field. The development and applications of CGE modeling in various countries including both developed and developing countries are also considered in this chapter.

2.2 Global Economics Integration

In the 19th century it was sometimes called "*The First Era of Globalization*" a period characterized by rapid growth in international trade and investment, between the European imperial powers, their colonies, and, the United States. It was in this period that areas of Sub-Saharan Africa and the Island Pacific were incorporated into the world system. Global economic integration generally means speeds up when trade restrictions have been lifted between nations, allowing a freedom of trading opportunity that may not have been previously there. Those on the pro side of the globalization divide argue that this can increase economic prosperity in all countries and leads to more opportunity among developing nations. It describes the phenomena of the local turning into the global, or the coming together of different aspects of the world into a single and identifiable state.

In the years of 1990s, the WTO was established and many parts of the world have created their own regional trade blocs as a means of promoting intra-regional and inter-regional trade and their economic growth. There are three main regional trading arrangements, which cover some seventy percent of world trade, are the North America Free Trade Area (NAFTA), the Asia-Pacific Economic Cooperation organization (APEC) and the European Union (EU). Many studies have attempted to assess the impacts of trade liberalization and other policy issues in these regions using Computable General Equilibrium (CGE) models, now widely accepted as an appropriate tool.

2.2.1 Overview

In the last four decades, the term of globalization has become popular. Modelski [16] an academic commentator who employed the term as late as the 1970s accurately recognized the novelty of doing so. The growing flows of trade and capital investment there is the possibility of moving beyond an international economy, to a 'stronger' version - the globalize economy in which, 'distinct national economies are subsumed and rearticulated into the system by international processes and transactions' as noted by Hirst and Thompson [17]. Globalization is very often used to refer to economic globalization that is integration of national economies into the international economy through trade, foreign direct investment, capital flows, migration, and the spread of technology, see Bhagwati, 2004 [18].

The geographical gap between the countries and regions cause the poor and rich between them. There are two gaps remain called object gap and knowledge gap. The first means the lack of valuable objects such as factories transportation infrastructure and material. The second one is the lack of accessibility to the ideas and the knowledge that is used in developed countries to generate economic value, as stated in Romer [19]. Each of these gaps imparts a distinctive thrust to the analysis of development policy. In term of an object gap highlights saving and accumulation, knowledge gap directs attention to the patterns of interaction and communication between a developing country and the rest of the world. The rationale behind economic integration is that by the removal of all barriers to own of produced and tradable goods and services, resources and ideas, their better allocation is achieved and therefore they are used with greater efficiency and provide greater total benefits.

There are three main approaches that a country may take to reducing its trade barriers: (i) unilateral trade liberalization; (ii) multilateral trade liberalization; and (iii) bilateral/regional trade liberalization. The first term, which means reduction of its trade

barriers is consistent with WTO rules, and can be implemented regardless of trade policies in other countries, that they usually do not choose to do so is generally attributed to domestic political pressure, with those domestic industries competing with imports opposing the proposed liberalization.

The second has many advantages; in particular that reduction in the trade barriers of other countries will benefit its exporting sectors, which then provide domestic political pressure in favor of liberalization. Such liberalization requires coordination as well as cooperation. This coordination has, since the end of World War II, been provided by the General Agreement on Tariffs and Trade (GATT) and subsequently the World Trade Organization (WTO), through successive 'Rounds' of negotiation. These negotiations have been successful in many aspects of trade liberalization, such as the general replacement of quantitative barriers to trade in commodities (e.g. import quotas) by tariffs, and reductions in those tariffs over time. They have however been less successful in liberalizing trade in services, and have only recently started to reform trade in textiles and other 'sensitive' products. Moreover, the process of multilateral talks is extremely time-consuming, and the final gains have not always been as high as hoped due to the many compromises needed in reaching a mutually accepted settlement. The last one, regional trade liberalization, is allowed under GATT/WTO rules subject to specified conditions on the tariffs set by members on imports from the non-members.

Building a regional community is understood to build a regional integration. Regional integration can be seen as a process through which independent states form a regional organization in order to increase regional cooperation and diffuse regional tensions or as a stage in such a process. Defining integration as a stage of a process towards regional integration lends itself to quantitative measurement of the outcomes of formation of integrated markets in goods, services, labor and capital. There have been many studies based on CGE modeling of regional integration in North America and Europe. However studies of integration between Asian economies are (relatively) less common. Now, the prospects of regionalism in Asia, especially East Asia, have increased dramatically. The assessing the outcomes of alternative East Asia Free Trade Areas have become more important and attract researchers to pay attention.

2.2.2 European and America

The theory of international trade proves that, subject to certain conditions, global free trade will lead to an efficient use of resources in all countries, so that all countries and all factor owners are at least no worse off, and possibly better off (subject to efficient transfers from gainers to losers). The General Agreement on Tariffs and Trade (GATT)

and its successor, the World Trade Organization (WTO) were established in order to further cooperation between member countries in the reduction of trade barriers. The process of multilateral negotiations is time-consuming and the final gain may not be as much as is theoretically feasible due to the need to compromise. The fundamental purpose of any regional effort is to link communities which share a common geographical locations and characteristics. A region represents a collection of societies which share a linked fate due to their interconnection, and which are all impacted by the region's challenges and opportunities.

In 1958, the European Economic Community started in the Europe by the Treaty of Rome. In 1967 evolved into the European Community by integration with the Coal and Steel and Atomic Communities and finally in 1993 European union (EU) have found by the Treaty of Maastricht. By now, the total GDP of the EU include of 27 member countries are nearly 500 million people and 13 trillion USD after accepted more 15 new countries and 2 member countries in 2002 and 2007 respectively.

Later in America continents, the North American Free Trade Area (NAFTA) were established in 1994 includes United State, Canada and Mexico. International trade agreements like NAFTA and the development of a European Community all demonstrate reduced economic competitiveness on a country-by-country basis, and increased competitiveness on a region by-region basis.

The motivating force behind the renewed interest in regionalism is emerging from several sources. First globalization in economy; second challenge consists of achieving sustainable development. Around the world, population pressures are pushing against environmental capacity. Increasingly, we are trying to balance economic growth, with environmental preservation and social equity. Part of the solution requires acting regionally. Finally, the US and several other countries are undergoing a devolution revolution.

More of the policy making and service delivery functions mandated by federal and state governments are being directed to the local level. Many of these-transportation, air and water quality planning and an increasing amount of social services planning-are required to be carried out at on a regional basis. Others are becoming regional on a voluntary basis.

The last decade of the 20th century saw resurgence in the use of regional economic integration accords as a key policy instrument by countries seeking to harness the potential gains of international trade and investment. The 1990s also saw a variety of social forces calling into question the development impacts of economic integration accords between rich and poor countries. With the turn of the Millennium came renewed calls for global economic integration accords to be more focused on economic development, including

the announcement of the UN Millennium Goals to the christening of the new WTO Doha round as the "Development" round. The events of September 11th and its aftermath also demonstrated the dangers of inaction on urgent global issues of inequality that exacerbate divisions within and between countries.

The 2003 negotiations for the formation of a US-Central American Free Trade Agreement (US-CAFTA) represents one of the most important tests of the global challenges faced by trade agreements between rich and poor countries. Unlike the previous major wave of regional integration accords in the 1950s and 60s among economically similar countries (such as the original EEC, the Andean Pact, and the Central American Common Market), the 1990s wave of regional integration efforts has sought to bring about accords between countries of very different economic status (most notably within NAFTA and APEC). While the 1960s saw the launching of regional economic integration among the Central American Republics, in the 1990s attention began to refocus on the possibilities of Central American countries developing free trade agreements with their NAFTA neighbors, particularly Mexico and the United States.

2.2.3 East Asian Regionalization

Over the last decade, East Asia has probably been the region that has been most active in seeking the rapid expansion of Free Trade Agreements (FTAs). Establishing the East Asian Free Trade Area Agreement (EAFTA), which includes ASEAN (the Association of Southeast Asian Nations), China, Japan and Korea, is the major goal for the whole region.

In fact East Asian countries were late comers in the international trade systems. Firstly, Japan became member of GATT in 1955, Korea in 1967, Singapore in 1973, Hong Kong in 1987 and finally China became a member of WTO only in 2002, followed by Taiwan and Vietnam was the last members in 2006. Before 1997, most Asian economies considered East Asian trade as an example of successful spontaneous regionalization is different in compare with the bureaucratic kind of trade regionalization exemplified by the European Union trade system.

However, since the 1997 crisis, East Asia is itself moving towards regional economic integration to varying degrees. ASEAN and China, through their various bilateral FTAs, are playing pivotal roles in the evolving dynamics of East Asian regionalism. The Asian financial crisis showed that rapid depreciation of one country's currency could adversely affect the export competitiveness of other countries, especially neighbors producing the same products for the same export markets. The crisis initially propelled countries to

explore options for monetary cooperation and macroeconomic policy coordination, but, by highlighting the economic interdependence of the region, it has also given rise to proposals for regional cooperation in trade and investment.

The first proposal for East Asian regionalism was made by the former Malaysian Prime Minister Mahathir in the early 1990s. The proposal, initially known as the East Asian Economic Caucus (EAEC), was to include ten members, the ASEAN countries, China, Japan and Korea in the bloc. It took years for the proposal of East Asian regionalism to be reconsidered. In 1997, ASEAN took a further step by proposing a summit meeting of ASEAN, China, Japan and Korea. The proposal was not favoured by Japan initially, but the outbreak of Asian Financial Crisis in 1997 led to Japan becoming involved. The forum of East Asian economies²¹ was initially intended to foster cooperation in solving the financial crisis and re-establishing financial stability in Asia. Subsequently the forum was extended to take economic cooperation into consideration. The obvious outcome of this is the proliferation of bilateral trade agreements between members. The success of the establishment of the ASEAN China Free Trade Area has dramatically changed Japan's perspective, leading to its following the same path.

China experienced an average real rate of growth of 10 percent a year and its exports quadrupled from some 62 billion US Dollars to USD250 billion US Dollars over the decade 1990 – 2000. Meanwhile, investment flows to China increased dramatically from some US3 billion to more than 40 billion US Dollars. There are significant benefits from being the first movers in such an environment. The greater tradability of many services and the growth of foreign direct investment have contributed to this focus in policymaking, Ghani *et al.*, [20].

Hence, it can be concluded such as East Asia regionalization is motivated by several factors namely that are (i) to reduce the risks of financial contagion and unusual exchange rate instability, the damaging effects of which were made clear by the Asian financial crisis and (ii) another key reason for the new trend is the perceived need by other economies of the region for stronger cooperation with China, both as a growing import market and as a rising competitor in export markets and (iii) the interest of business communities in getting preferential access to foreign markets, especially when these are imperfectly competitive markets in which some form of establishment is required.

Other factors include the move by many economies, especially the more developed in the region, to lower their average tariffs; the growing recognition of the value of harmonizing standards and regulations, if these are not to impede trade; and the higher concentration of trade among regional partners, especially in East Asia. These changes have affected countries' assessment of the costs and benefits of entering into preferential

TABLE 2.1: Trends of per capita GDP in ASEAN and selected trading partner countries/regions

Country/Region	1998	2003	2007	2008	2009	Ratio 09/98
In US \$						
ASEAN	965	1,332	2,267	2,592	2,533	2.63
China	817	1,270	2,560	3,404	3,678	4.5
Japan	30,527	33,134	34,268	38,271	39,731	1.3
Rep. of Korea	7,724	13,451	21,653	19,162	17,074	2.21
India	409	523	945	1,021	1,031	2.5
Australia	20,314	27,143	44,745	48,951	45,587	2.24
New Zealand	14,559	20,017	30,927	30,653	27,259	1.87
USA	31,858	38,324	46,630	47,393	46,381	1.46
EU27	19,081	23,549	34,325	37,068	33,052	1.73
In PPP International Dollar						
ASEAN	2,756	3,620	4,526	4,732	4,840	1.76
China	1,997	3,217	5,388	5,999	6,567	3.29
Japan	23,882	27,222	31,943	31,943	31,943	1.34
Rep. of Korea	13,413	19,697	24,662	24,662	24,662	1.84
India	1,291	1,713	2,329	2,329	2,329	1.8
Australia	25,186	30,859	35,314	35,314	35,314	1.4
New Zealand	17,707	22,354	25,641	25,641	25,641	1.45
USA	31,858	38,324	44,823	44,823	44,823	1.41
EU27	21,869	26,346	32,012	32,701	31,600	1.44

Source: ASEAN Community in Figures ACIF 2010 [21].

agreements. Some countries are also seeking to forge new agreements as a defensive response to arrangements being created elsewhere. Agreements on economic cooperation offer opportunities to build a sense of community or to repair past tensions between neighboring economies. Membership of regional trading arrangements and informal economic cooperation forums provides occasions for numerous meetings between senior officials, ministers, and leaders, and it has been seen as a crucial component of the community building that has taken place in the region, especially in ASEAN.

During the last three four decades from the late 1960s, regional integration in the East Asian region was associated almost exclusively with the initiatives of the ASEAN in 1967. In the first decade, the share of intra-ASEAN trade in the total trade of member countries was between 12% and 15%. In a single ASEAN region, where producers will benefit from better supply or resources and ability to serve larger markets, while consumers will have enjoy greater variety and lower prices for consumption, is the basic element of economic community. The table below shows some key statistic of ASEAN.

AFTA was signed to lower trade barriers and increase cross border trade. ASEAN also plans an economically integrated ASEAN Economic Community in 2015. In order to achieve this goal and to sustain its stellar economic performance, addressing the region's current and future demand for infrastructure will be critical. There is a need to build an

TABLE 2.2: Keys ASEAN statistical factors 2009

	Total land area km ²	Total population	GDP at current market price		GDP per capita	
			\$US Mn	in US million PPP\$	\$US	PPP\$
Brunei Darussalam	5,765	406	10,759	20,071	26,486	49,411
Cambodia	181,035	14,958	10,359	26,935	693	1,801
Indonesia	1,860,360	231,370	546,865	964,220	2,364	4,180
Lao PDR	236,800	6,128	5,579	14,398	910	2,350
Malaysia	330,252	28,307	193,108	384,787	6,822	13,594
Myanmar	676,577	59,534	24,973	65,093	419	1,093
Philippines	300,000	92,227	161,358	325,105	1,750	3,525
Singapore	710	4,988	182,702	248,212	36,631	49,766
Thailand	513,120	66,903	264,323	540,054	3,951	8,072
Vietnam	331,051	86,025	96,317	267,611	1,120	3,111
ASEAN	4,435,670	590,844	1,496,341	2,859,487	2,533	4,840
CLMV	1,425,463	166,645	137,228	374,037	823	2,245
ASEAN6	3,010,207	424,200	1,359,113	2,485,450	3,204	5,859

Source: ASEAN Community in Figures ACIF 2010 [21].

ASEAN regional infrastructure initiative based on a shared strategic vision with strong commitment of all participating economies. The region has come a long way from the days of national autarkic and inward-looking policies. It has improved its ability to respond to the challenges of regional integration and globalization; in so doing, it has succeeded in transforming itself into a key player in the world economy, ADBI 2010 [22].

D. Ariyasajakorn, *et al.*, [23] noted that during the past decade, studies have confirmed that regional integration stimulates economic growth and flows of international investment, which in turn lead to welfare improvement, for each country involved in the integration process. Nevertheless, size and distribution of those impacts may vary depending on many factors, e.g., how the integration takes place, see Pal *et al.*, [24]; Sudsawasd and Mongsawad, [25] and size of the trading partners in Park [26] and Plummer [27]. Many empirical research indicates that FTAs induce economic growth for each economy involved in the agreement. The benefits normally come in the form of higher GDP. Unfortunately, welfare loss may occur due to trade diversion, which will cause negative terms-of-trade effects, see also Sudsawasd and Mongsawad [25].

The combination of countries included in the negotiation proves to be an important factor in determining economic gains. For many possible combinations of countries, the expected benefits from FTAs would increase if advanced economies joined the agreements see Plummer [27]. According to the empirical estimates, openness with Japan, the United States, or EU will greatly stimulate economic growth for ASEAN countries. Patterns of trade prior to the FTAs have been shown to be important factors in

determining trade patterns and gains after integration.

2.3 Transportation Infrastructure Investment

Transportation infrastructure investment has direct effects on passenger and freight transport, it leads to economic development effects occur as the end result. The improvements of transportation infrastructure can reduce household out-of pocket costs for personal trip, hence increasing disposal personal income through rising the living standard and consumer spending. In addition, transportation improvements can reduce direct costs for freight transport, as a result the production costs of the firms reduced.

Regional transportation infrastructure linking regions are specially important for developing countries. According to Birdsall 2004 [28], regional public goods in the developing countries remain underfunded despite their potentially high returns compared with traditional single-country-focused investments. The high returns arise from positive cross-border spillover effects which are not necessarily taken into account in each individual country's investment decisions. He estimates that regional public goods receive only 2.0 to 3.5 percent of total official development assistance. Transport volumes and GDP have been generally developed in parallel in the past. This has been true for both developed and developing countries.

The link between transport and the economy has been the object of numerous of literature. Meersmand and Vande Voorde [29] use elasticity estimation to make assessment of the transport demand sensibility to economic production. Particularly, the study estimates the elasticity of freight transport to the industrial production in Belgium. In India, study of Kulshreshtha and Nag [30] estimated inter-urban railway passenger transport using cointegrating VAR model. In France, Julien [31] uses the transport elasticity to economic production to assess the link between the transport and the economic growth. The study shows the rise of the average distance of transport has often been identified as an explanation of the coupling.

2.3.1 Background

The transportation infrastructure investments can reasonably be expected to reduce transport costs and promote trade between regions and between regions in the country with the rest of the world. The economic effects of transport infrastructure on the economy can be distinguished by temporary and permanent effects. Transportation

infrastructure improvement is essential to the realization of economic integration and dispensable to its future success not only in the regional but also global wide.

The improvement of transportation infrastructure needs to be accelerated to enhance physical connectivity, as well as encourage resource-sharing. In order to promote regional trade and investment, improve countries competitiveness, and raise domestic output, it is important for countries and regions to be physically connected through various modes of transportation, such as roads, railways, airways, and ports and shipping.

Recent decades, we witnessed the improved and integrated transport and logistics systems in numerous economic communities such as ASEAN, NAFTA and EEU is an integral part of the regional integration initiative. Infrastructure plays an important role in promoting rapid economic growth and making this growth more inclusive, by sharing the benefits of growth with poorer groups and communities, particularly in remote and isolated areas and small and landlocked countries. Infrastructure facilitates the poor's access to basic services and helps increase their income generating capacity. Physical connectivity through regional transportation infrastructure networks improvement is crucial for enhanced regional cooperation and economic integration, see Kuroda [32].

2.3.2 Roles of Transportation Infrastructure

Transportation infrastructure spending accounts for a significant proportion of national income and consumption in many countries, any reform affecting the sector is likely to have wider repercussions on the economy. Empirical evidence indicates that infrastructure spending has a positive and statistically significant effect on long-run economic growth, World Bank [33]. A UNESCAP [34] study on infrastructure in developing Asian countries has shown that road transport and electricity, in particular, play a key role in poverty reduction. Through efficient transportation infrastructure improvement is binding the cooperation of economic regions getting closer, see Yong [35].

Transportation infrastructure development is necessary to improve resource sharing and efficiency in the region to provide basic accessibility, movements and promoting trade, economic integration and among countries. Studies show that the Greater Mekong Sub-region³ could save the region US\$ 200 billion in total energy costs (roughly 19% of costs) through energy exports. Note that all of the GMS countries are also ASEAN member countries. A reduction in costs will bring about significant benefits, particularly for smaller GMS economies such as Lao PDR, with a GDP of US\$3.4 billion; even Thailand, with a GDP of US\$206 billion, is expected to benefit from a reduction in total energy

TABLE 2.3: Land Transport Indicators in ASEAN Countries

	Roads, total network (km)			Roads, paved (% of total roads)			Rail lines (total route-km) (per 100km.sq.)		
	1991	2000	2005	1991	2000	2005	1991	2000	2005
Brunei Darussalam	25.82	19.93	20.10	32.00	34.70	78.06	0.00	0.00	0.00
Cambodia	19.76	20.02	21.13	7.50	16.20	6.29	0.33	0.33	0.36
Indonesia	16.48	18.69	19.34	45.30	57.10	58.00	1.90	1.91	1.93
Lao PDR	5.95	9.17	13.18	16.00	44.50	14.41	0.19	0.20	0.21
Malaysia	27.31	19.98	29.94	73.00	75.30	81.32	0.67	0.60	0.60
Myanmar	3.77	4.13	4.13	11.20	11.44	11.44	0.33	0.38	0.38
Philippines	53.57	67.24	66.68	14.00	21.00	21.64	0.16	0.16	0.16
Singapore	423.97	451.62	456.08	97.10	100.00	100.00	0.00	0.00	0.00
Thailand	10.20	11.19	11.19	88.40	98.50	98.50	0.75	0.79	0.79
Viet Nam	29.60	65.49	67.47	23.90	25.10	25.10	0.86	0.95	0.81

Source: World Bank 2008b [37].

costs. The gains owe to large increases in energy demand over the coming years, uneven resource endowments across the region, GMS [36].

The trend of transportation infrastructure improvement shows an improvement in the ranking of each country, it also reveals huge gaps in its availability across ASEAN member countries. These gaps also seem to have widened, rather than narrowed, over time. Similarly, a widening gap is also evident in land transport. Over 15 year period, roads have improved in most countries, but in terms of rail lines, very minimal improvement can be observed (Table 2.3).

The gaps are also evident in terms of paved roads as a proportion of total roads (6.5% in Cambodia vs. 100% in Singapore in 2005). These gaps in infrastructure development need to be addressed if the development gap-both within and across countries in the region-is to be reduced. Substantial resources will be needed in order to bridge these infrastructure deficits, particularly in low-income ASEAN countries. The main challenge is to mobilize regional savings to meet these gaps in low income countries.

2.3.3 Freight Transport

The current global economy with major trend of globalization and regionalism, the world economy becomes more integrated, the development of international trade is greatly stimulated, and transportation, which is a primary infrastructure in terms of international freight and passenger transport not only in Asia region but also in other economy communities which experiences a remarkable development. The role of freight

transport is very important in the linkages between it and the economy. Improvements in freight transport can be expected to have important economic effects. Either lower costs or better service in freight movement have a positive effect on all firms engaged in the production, distribution, trade and/or retail sale of commodities.

Reducing the transportation cost of commodity flows means that any production or distribution facility can serve a wider market area, with potential gains from scale efficiencies. It also means a firm can draw supplies from a wider area with potential gains in terms of the cost, quality of parts and materials coming to the firm. In recent years, trucking costs have been falling and reliability has been improving. Businesses have tended to respond by buying more transportation and using it to reduce the other components of logistics costs (e.g., through fewer warehouses or lower inventories). As we shall see, the tendency of managers to respond this way to lower costs and/or improved quality of freight transportation is a fundamental source of the economic benefits stemming from improvements in the freight transportation system, see ICF [38].

ICF [38] describes how an efficient and reliable freight transportation system helps to generate improvements in economic productivity. The study used the benefit-cost models to conduct evaluation of highway investments, it shows that the speed and reliability of the freight system can be expected to worsen as vehicle traffic grows and congestion increases. A development could force shippers and carriers into costly redesign and restructuring of their systems with higher logistics costs and a consequent drop in productivity. Improvement in the performance of the freight system, with concomitant gains in national productivity, will require significant gains in the battle against congestion.

The investments in transportation infrastructure can lead to generative effects and growth in the national economy. The efficiency and reliability of the freight transportation system affects economic productivity, and many economists would argue that productivity is the most important determinant of economic performance. Freight transportation enhancements that reduce the commodity transport costs to and from markets are critical to economic expansion. This is because the movement of goods is what economists term a factor input in the production of goods. Much like labor and capital, transportation costs affect directly the price of goods and services and the profits of producers. Consequently, investments that reduce the cost of moving goods to and from markets can help to increase and sustain economic growth, ICF [38]. The figure below shows the relationship between transportation infrastructure investment and economy.

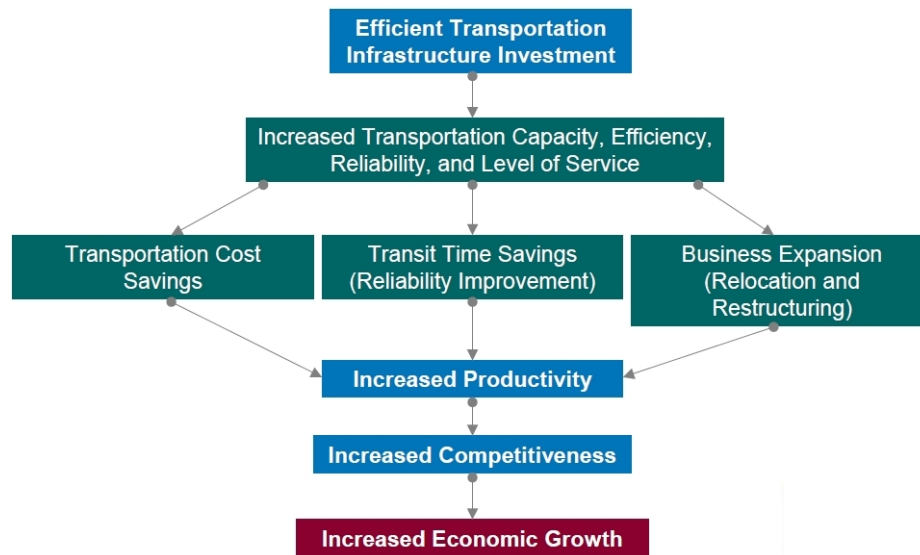

Source ICF [38].

FIGURE 2.1: Transportation infrastructure and Economy

2.3.4 Passenger Transport

Passenger transport may gain benefit from transportation infrastructure improvement. Savings in time can be used for activities other than traveling, allowing labors and firms to be more productive or to have more time for recreational activities. For example, when a business reduces its delivery times as a benefit of a transportation improvement, it may become more competitive and gain a larger customer base. The saved time can then be used in production activities. Savings in travel time can also be valuable for commuters who gain additional time for work, household activities, and recreational activities as travel times to destinations are reduced NCHRP [39].

Estimating travel time savings is an essential component of virtually any economic analysis of a proposed transportation investment. Despite the obvious desirability of definitive values for this key factor, there are several significant issues that make a precise assessment of the value of travel time savings elusive.

According to Wardman [40], the value of travel time savings has two components: the opportunity cost of the time spent traveling and the relative disutility of that time. For example, waiting 10 minutes for a bus produces greater disutility than riding the bus or traveling in an automobile. Mohring et al. [41] found that people value the time spent waiting for a bus quite differently (more negatively) than the time actually spent en route. Disutility also may increase over the course of a journey. For example, disutility may be low for the first quarter-hour of a commute, but may subsequently increase as the traveler begins to experience discomfort and boredom.

A loss in time may be inconvenient and may require individuals to take time away from other activities. A small time savings may not be significant enough, however, to apply to any other activity. In other words, an increase in the travel time may well be of greater cost than a comparable savings in travel time is valued as a benefit, see Wardman [40].

2.4 CGE Modeling Analysis

2.4.1 Background

The development of computable general equilibrium models (CGE) goes back a long way in economics, both at a theoretical level and as a tool for empirical analysis. General equilibrium theory and modeling have proved to be relevant and useful for understanding economic interactions between markets and agents in complex modern economies and the determination of prices and quantities as a result of the latter interactions. CGE models have been developed and used to address a wide range of theoretical questions and empirical/policy issues, in the fields of macroeconomics, international trade, public finance, and environmental analysis, among others. GEMs are used for many purposes, including simulation of policy changes and response to exogenous shocks, as well as forecasting (mostly macroeconomic) variables.

In the years 1960s, CGE models with endogenous prices grew out of the multi sector planning models. Particularly, Johansen [42] developed the first empirical model with a multi-sector structure and endogenous prices to analyze economic growth in Norway. Multi sector planning models were based on social accounting matrices, integrating fiscal, balance-of-payments and national accounts. Harberger [43] followed suit, providing the first numerical application to tax policy analysis in a two-sector model. Scarf [44] contributed advances in the development of algorithms for solving increasingly complex models. Since then, the development of CGE models has grown exponentially. Their fields of application include fiscal policy and optimal taxation by Slemrod [45], income distribution by Bandara [46], sector development by Robinson *et al.*, [47] for agriculture, and environmental issues by Kokoski and Smith [48].

More recent CGE models on trade issues have provided measurements of the effects of lower bilateral and multilateral tariffs stemming from regional free-trade agreements, particularly within the European Union. These models allow the assessment not only of aggregate trade, productivity, and output effects of trade integration, but also of

welfare, transfer, and labor mobility effects, both across sectors and across workers with different skills such as Rollo and Smith [49], also see Keuschnigg and Kohler [50].

CGE models are based on general equilibrium theory. The general equilibrium is achieved when demand equals supply in all markets at prevailing prices, and assuming constant returns to scale, zero profit conditions are satisfied for each industry, see Shoven and Whalley [51]. The main characteristic of a CGE model is that the economy must satisfy rigorous microeconomic constraints, specified by a set of equations that reflect the optimizing behavior of economic agents, i.e. firms, household, and government, subject to technological and budget constraints. Thus such models give an understanding of the whole economy by starting from a solid micro foundation of individual markets and agents' behavior. While CGE models have at their core production and consumption structures, they also incorporate the standard macroeconomic requirements, e.g. household income must be equal to consumption expenditure and savings, countries must be in balance of payments equilibrium, saving equals investment, and so on.

Given optimization by economic agents, subject to the firms' technologies (different in each sector within a country/region), household and government preferences, fixed national factor endowments, and implemented policies; the other variables in CGE models may be determined because these variables are all interdependent. The linkages are generated according to sets of accounting identities: for example, each household obtains its income from wages, rents, and government transfers, while household expenditure flows to private consumption, income tax payment, and saving.

The analysis of an economy in general equilibrium is crucially based on the Arrow-Debreu theorem, in what is sometimes called the Arrow-Debreu [52] model. The theorem is important in that it provides a rigorous proof of the existence of a general equilibrium and, further, of the uniqueness of that equilibrium. That is, such an economy does not generate multiple equilibria, some of which may not be stable. The basic CGE approach is to take cross-sectional data from a single base period, impose changes on the underlying data, and observe how the endogenous variables adjust. The model size can vary from a single country to a global level with many countries. In addition, the models can be designed to capture many complicated economic aspects and to allow or prohibit flexibility in prices and quantities, depending on the purpose of study.

CGE models have been used extensively in the analysis of various policy issues, e.g. fiscal and international trade policy, Shoven and Whalley [53], economic integration and other regional trading arrangements, see Lloyd and McLaren [54], energy and environmental issues by Bhattacharyya [55], economic development and the distribution of income by

Decaluwe and Martens, [56]. A family of models termed CGE models focuses on issues related to resource allocation across different supply sectors, relative prices of goods and factors of production, and welfare levels of different income groups. Economy-wide planning models developed between the 1950s and 1970s - were predecessors to CGE models. Planning models used in countries with a large government role in determining sector prices and quantities-combined macroeconomic policy analysis with aggregate and sector-level budgeting and planning, Romulo *et al.*, [57].

Baldwin and Venables [58] presented in a survey study that general equilibrium modeling of trade issues can be categorized into three generations. The first generation models were usually developed using the traditional assumptions of perfect competition and constant returns to scale. A common feature of such models is that consumers in each country/region do not regard imported goods as perfect substitutes for domestic goods, and do not regard imports with different origins as perfect substitutes for one another. This, usually referred to as the 'Armington assumption', is used so that the two-way bilateral trade flows in such goods observed in reality can be modeled as being produced by perfectly competitive sectors in each economy.

However, the second generation models, sometimes known as 'New Trade Models' are built under assumptions of imperfect competition and increasing return to scale. These characteristics are often introduced through monopolistic competition using the Dixit-Stiglitz 'love of variety' utility function. In this class of monopolistic competition models, products are not homogenous, and an increase in the number of varieties available to consumers will, *ceteris paribus*, increase their welfare. An alternative approach to modeling two-way trade is to specify that firms in some sectors behave as oligopolists.

Finally, the third generation models incorporate dynamic aspects into the models by introducing investment and growth effects. The argument for this type of model is that static models consider only the effects of resource reallocation within a single period, ignoring the possible long-run accumulation effects. Such models may be fully dynamic, being run over a large but finite number of time periods, or quasi dynamic in that in each time period the model is solved using the current endowments of factors, as in the earlier models, and then the changes in investment and population growth are carried through to the next time period, and so on.

Even though the structure of the first generation models is relatively less sophisticated than those of the succeeding generations; they are still widely used for trade discrimination analyses. Lloyd and McLaren [54] argue that such CGE models are very useful tools for assessing the discriminatory effects of Regional Trading Arrangements (RTAs), especially when the predictions of welfare effects of trade discrimination via RTAs on

member and non-member countries are still ambiguous. Moreover, in models with many countries and goods the predictions of second generation 'New Trade Models' may be very similar to those from first generation variants.

2.4.2 CGE Modeling in United States

Many multiregional CGE models have appeared, their approaches and purposes vary greatly in United States. In 1984, Liew [59] proposed a means of including explicit interregional trade flows in a multiregion model of the ORANI style, but excluded spatial price differentiation or interregional transportation costs. In 1988, Higgs *et al.*, [60] developed a hybrid (top-down, bottom-up) version of ORANI. An application of Johansen-style developed by Morgan *et al.*, [61] for a nine-region, six-sector tax model for United States.

Buckley [62] develops interregional computable general equilibrium (ICGE) models which is explicitly includes transportation and wholesaling services and the costs of moving products based on origin-destination pairs. In this study, the authors outline a three-region, five-sector operational ICGE model of the United States. The ICGE models combine the multi-sectoral CGE heritage of Johansen (1960) with the multiregional spatial modeling efforts dating from Isard's [63] ideal multiregional input-output model; resulting in a Walrasian price endogenous, commodity balance model with multiple consumers. Three feedback mechanisms are included in ICGE: the inter-industry, interregional, and consumer based multipliers. These occur under conditions of factor substitution, intraregional labor mobility, interregional substitution of goods produced for intermediate input and final consumption, explicit inclusion of transportation and wholesaling services in the spatial movement of goods, and fixed quantities of net international trade.

2.4.3 CGEEurope Modeling Development - IASON Project

In Europe, one of the most important challenges for the European Union is the enlargement of the European Union to the East. The economic implications of the Eastern enlargement play an important role in the current debate. A number of CGE models were developed to analyze the effects of the enlargement from the European Union perspective. Some of them also evaluate the costs and benefits of integration for the EU. In 1995, Brown *et al.*, [64] evaluate the effects of the EU-CEEC (Central and Eastern European countries) integration using a specially constructed version of the University of

Michigan CGE world trade model. The model includes 8 countries/regions, where Hungary, Poland and former Czechoslovakia are individually modeled. The European Union is further divided into three groups: EU-North, EU-South and EU-EFTA (Austria, Finland and Sweden). For each region, 29 production sectors are specifically modeled, where manufacturing and services sectors are characterized as being monopolistically competitive with free entry. The model is static and the base year for the calibration is 1992. They analyze the EU-CEEC integration through: the formation of CEFTA, the implementation of the CEEC-EU free trade agreements, the elimination of tariffs and non-tariff barriers. Their results show that both EU and CEEC reap gains although the gains are larger for the Eastern European economies. The effects on the non-European regions are negligible.

Piazolo [65] develops a dynamic Ramsey-type open economy CGE model for Poland to evaluate the effects of its integration into the EU. The model distinguishes one production sector and one type of commodity. PRINCE is calibrated on the Social Accounting Matrix for the year 1996. EU integration membership is captured through tariff reduction, border cost reduction, reduction of technical barriers to trade and net EU-transfers from Brussels to Poland. The welfare gains show that Poland will benefit directly from the EU membership.

CGEurope is a multi-regional, and in its extended version developed for IASON multi-sectoral CGEurope is a multi-regional model for a closed system of regions, treating separately each region and linking them through endogenous trade. The world is divided into a large number of regions. Each region shelters a set of households owning bundle of immobile production factors used by regional firms for producing goods and services.

2.4.4 Multi-Regional CGE model

In the last two decades, the development of regional and multi-regional CGE modeling has experienced an upsurge in interest from academics and policy makers. Different models have been built for different regions of the world. Researchers have contributed to these developments through the specification and implementation of a variety of alternative models. Recent theoretical developments in the new economic geography bring new challenges to regional scientists in general, and to interregional CGE modelers in particular. Experimentation with the introduction of scale economies, market imperfections, and transportation costs is expected to provide innovative ways of dealing explicitly with theoretical issues related to integrated regional systems.

The potential uses of multi-regional and interregional CGE models include the analysis of transportation planning policies with ranging effects on regional and national economies. National transportation system planning is a widely institutionalized process in several countries. The use of model-based analytical procedures is common in infrastructure planning. This includes the application of conventional input-output methods for forecasting freight movements. Nevertheless, the feedback impact of transportation actions on the regional and/or national economies is not fully accounted for in these procedures. In recent years, the development of improved techniques was the focus of several efforts joining the transportation and economics research fields in the USA by Friez *et al.* [66] and the EU by Brocker [67], along with similar efforts in several Asian countries has done by Miyagi [68].

2.4.5 CGE Models in Asian Countries

Numerous studies have explored the possible outcomes of alternative East Asian countries. The focus of studies varies considerably, from a narrowly defined North-East Asia nation group - China, Japan, and Korea - to a broader East Asia group which incorporates the ASEAN economies. Some studies also include India, the justification being that there is an empirical evidence of a strong economic relationship between ASEAN and India. At the same time, the methodology used for analysis of Regional Trading Agreements also differs across studies, encompassing, for example, gravity models and cost-efficiency studies.

2.4.5.1 Japan Case

In 1985, Kanemoto *et al.*, [69]. developed model that considers three benefit measures of a large transportation improvement in a general equilibrium framework, the Marshall-Dupuit consumer's surplus, the compensating variation, and the compensating surplus. They examine (i) whether or not the measures can be reduced to the area to the left of a suitably defined transportation demand curve (ii) the measures are expressed as functions of various price and income elasticities which can be empirically estimated and we analyze factors affecting the magnitudes of the general equilibrium benefit measures, and (iii) the general equilibrium measures are compared with the partial equilibrium measures.

Since the 1990s, CGE analysis has been widely developed. Kobayashi *et al.*, [70] proposes a dynamic multi-regional growth model with free mobility of capital and population, the model's economic system consists of multiple cities interconnected by high-speed railway (HSR) systems in which each city consisting of one production sector and residential land use. The HSR systems provide production sectors of different cities with the opportunity of face-to-face communication for knowledge production. It is emphasized how differences in geographic and qualitative factors of high-speed railway systems may affect regional economic development. The model simulates the dynamic processes of economic development of city systems.

Mun [71] presents a general equilibrium model of a multi-city economy with many types of industry where cities are linked by a transport network. The model determines city size distribution, industrial location, inter-city trade patterns, wages, prices of goods, land rent, and the utility level of households. He conducted numerical simulations to investigate how different transport network patterns affect city size distribution and the welfare of households. It is shown that improvement in the transport network such as highways induces concentration of firms and households in a particular city, and that such concentration significantly increases welfare. Reduction in transport cost improves the welfare of people. Especially, the extent of such welfare improvement is very large when industrial structure and city size are changed. Besides, it shows the different historical paths of network improvement may cause drastically different city size distributions.

Miyagi [68] develops a spatial computable general equilibrium (SCGE) model aimed at estimating the indirect economic effects arising from a large scale of transport project (Tokai-Hokuriku Expressway) in the Chubu region in Japan. They adopted a joint parameter estimation of calibration technique, statistical estimation for estimating the Japanese inter-regional account consisting of nine major regions with the national account being the benchmark equilibrium data. The study reports that economic effects of the project extended over whole country through the so-called multiplier effects of the economy and the SCGE model is an effective tool for assessment of the incidence of the wide economic benefits from the transport investment.

Ishiguro *et al.*, [72] develops international trade model taking account of ocean carriers' behavior and scale economy based on SCGE framework. The model was applied to trade between Japan and six Asian countries respectively with an industry wide scale economy is considered on an ocean carrier sector which plays an important role in the international trade. From the study, the authors find that (i) it is supposed improvement of productivity of ocean carrier sector at the first case study (ii) it is reaffirmed that ocean carrier plays an important role in the international trade. Getting larger

the proportion of ocean carrier sector, trade amount is strongly influenced with scale economy. Freight rate reduction causes two results (a) profit of ocean carrier decrease and cost of import/export companies decrease and (b) effect of latter change is larger than that of former change in general. While scale economy parameter get larger, a country, which has large ocean carrier sector, receive more benefit from international trade.

Sakamoto [73] develops a multi-region computable general equilibrium model, which analyzes the influence on a regional economy of a reduction in the transportation cost in term of the logistics cost. Logistic competition has accelerated with recent economic development. The study analyzes the economic effect on the Northern Kyushu region and on surrounding regions of the cost reduction caused by the logistic policy of the Northern Kyushu region. In the production system, the transportation industry engenders transportation costs and these are added to the price of the commodity. Reducing the transportation cost in the Northern Kyushu region is expected to attract firms and increase the amount of labor, as well as revitalize the regional economy. On the other hand, the opposite results were seen, with negative activation of the Northern Kyushu region leading to reduction in the rest of Japan.

The CGE study have concerned trade liberalization for Japan has been developed by Takeda [74] with consideration on regional effects based on the Interregional Input-Output Table for Japan 2000. In addition, concern has grown alongside the escalation of regional disparities. Accordingly, the research provides a quantitative investigation of the regional effects of trade liberalization in Japan. They use a bottom-up CGE model for Japan with eight domestic regions. The authors' findings are (i) liberalization increases welfare and GDP in Japan as a whole; (ii) the effect on GDP and welfare in individual regions varies significantly across regions. As a result, trade liberalization exacerbates existing regional disparities. These results indicate that if policy makers have an interest in regional disparity, they should implement some form of redistributive policy in conjunction with trade liberalization.

2.4.5.2 China Case

In China with the economic growth in past decades, increasing regional disparity has become a severe problem and alleviation of regional disparity has been the key issue of regional policy. The economic linkages across regions are increasing with liberalization and privatization of economic system and then pose impacts on regional economy. There have numerous studies about regional in China. Its rapid economic growth over the past quarter-century has not resulted in convergence between regions. Yang [75] attributes

the widening inequality in China to fiscal and credit policies that have been biased towards urban activities; the establishment of special economic zones in coastal regions with superior tax treatments and preferential resource allocations. Fan and Zhang [76] concerned with the link between infrastructure provision, education and productivity growth, leading to rural economic development. In addition, Liu and Li [77], notes a need to strengthen linkages between domestic banks and the non-state sector.

Those studies agree that policies and reforms in China should be directed at reducing inequalities between regions. Many policy-makers may assert that transport infrastructure is the highest priority for the policy reforms. However, in existing models, regional price differentials play important roles in multi-regional settings, while transport does not receive much attention. Ando *et al.*, [78] develop a spatial CGE model that explicitly considers the transport sector and fob/cif prices. The model is evaluated by comparing the benchmark equilibrium for China with survey-based regional I-O and interregional I-O tables for 1987. The structure of Chinese economies is summarized using information obtained from the benchmark equilibrium computation. This includes regional and sectoral production distributions and price differentials. The equilibrium for 1997 facilitates discussion of changes in regional economic structures that China has experienced in the decade.

Zhang [79] develops an empirical model to test the spatial spillover effects of transport infrastructure on economic growth. It uses spatial econometric techniques and provincial panel data of China from 1993 to 2004 to analyze the contribution of transport infrastructure to the economic growth of local province and its spatial spillover effects on the economic growth of other provinces. The study found that transport infrastructure and economic growth of China show an evident pattern of spatial clustering. They largely congregate in developed eastern coastal regions, forming a gradient gradually diminishing from east to west; Output elasticity of local transport infrastructure is 0.106, between the values calculated by early researchers with time series data and panel data. And spatial output spillovers from transport infrastructure are largely positive, but evidences of negative spatial spillovers are also found with population density spatial weights matrix model.

Most recently, Horridge *et al.*, [80] propose SinoTERM (The Enormous Regional Model - is a "bottom-up" CGE model of Australia which treats each region as a separate economy) a multi-regional CGE model of China to analyze the regional economic impacts of region-specific shocks. Such shocks could major transportation infrastructure investments in an effort to accelerate economic growth in the lagging inland provinces. They used a 63 sector, 10 region aggregation of the SinoTERM master database to model the regional economic impacts of the construction of the Chongqing-Lichuan railways.

2.4.6 CGE Models Analysis in Vietnam

In the last two decades, Vietnam has achieved high rates of economic growth. In the period of the years 2000-2009 witnessed remarkable improvements in Vietnam's performance from real aspect to social issues and economic institution, the annual average growth of the economy have been remaining about 7.3%. However, beside the over-excitement the country's economy faces with the continuously increasing of chronic trade deficit which have been causing to the macroeconomic instability. Since year 2007, when Vietnam became the official member of the World Trade Organization (WTO), the service sector felt down into the trade deficit induced by deficit in freight transport services and insurance services.

A number of studies make use of CGE models to evaluate the economy-wide effects of the ongoing trade liberalization in Vietnam, including efforts related WTO accession. Most of them investigate effects of changes in Vietnamese trade barriers, changes in trade barriers abroad such as changes in the extent of market competition, and technology. Most papers identify a positive average income effect of integration, while the effects on inequality and poverty are ambiguous. Transportation investment improvements have become increasingly important to developing countries and Vietnam is not an exception. Consequently, numerous empirical studies on the effects of transportation improvements have been conducted.

However, there is limited research using CGE models to examine the economy wide impact of that in Vietnam's economy. A strong point of CGE models is that they enable us to assess the impact on various aspects of the economy simultaneously. For that reason, this section aims to contribute to the literature by employing a CGE model to investigate effects of transportation infrastructural investment on the Vietnamese economy. The next subsections provide an overview of the current situation of economic model namely Input-Output analyses in Vietnam and the CGE modeling related to the issue.

2.4.6.1 Input-Output Analysis

In the nearly three decades since it began market-oriented reforms, Vietnam has experienced rapid growth and substantial structural change. Naturally, Vietnam's remarkable economic performance has stimulated commentary on the observable features of Vietnam's economic success and research into causes of these outcomes. So far, much of research into the recent history of Vietnam's economic growth and structural change has been of a detail qualitative nature for example see Kokko [81], Fforde [82]. Their

researches has discussed key features of Vietnam's recent economic improvements, such as the rapid growth and increased diversity of export. rapid GDP growth, industrial growth. There have been only few quantitative investigation of Vietnam's recent economic success.

Their have researches of Le *et al.*, [83], and Tran [84] using Solow (1957) model growth accounting framework to decompose changes in GDP into changes in factor inputs and total factor productivity. Pham *et al.*, [85] use the multi-sectoral dynamic input-output model to decompose changes in sectoral output and value added into contributions by shifts in various demand-side variables.

During the last decade, Input-Output model has been widely used to assess the impacts of changes in an economy, it is also an important tool to make forecasts and the results from an Input-Output model are very helpful in policy-making process. Many scientific findings in economics have to give credit to the Input-Output approach developed by Leontief. Numerous of studies on Vietnam economic using Input-Output analysis have been conducted. In 2007, in Bui *et al.*, [86], the authors develop study which has gone one step further to develop a new concept, economy-wide multipliers to assess the modernization process in Vietnam's economy, multi-regional Input-Output table of 7 regions and 10 aggregated sectors in Vietnam is used for calculation with the help of the multipliers from the Input-Output based approach showed that one important area, agriculture, has been not received an adequate policy in order for it to develop to fully meet with its potentiality. Bui *et al.*, 2008 [87], presents a technique on compiling multi-regional input-output framework. The main objective of the research is to provide an adequate and reliable Input-Output database that could effectively serve as bases in the conduct of intra-regional as well as inter-regional economic and environmental studies.

Francisco *et al.*, [88] deals with an economic assessment based on single country or intra-national I-O tables available provides therefore the technical insights into how the proposed research project shall be initiated and pursued, the consideration paid to three countries includes Vietnam, Cambodia and Thailand. And this can be done by looking first at the I-O data of each country in the region. One of the finding from the study is the net export earnings, estimated as the difference between the per unit gross earning and per unit import requirement to produce export goods, are then calculated to be, as follows: Cambodia -0.74 ; Thailand -0.60; Vietnam -0.70.

2.4.6.2 CGE Modeling Analysis

So far, a number of studies make use of CGE models to evaluate the economy-wide effects of the ongoing trade liberalization and simulations of future effects of a specified set of policy changes in Vietnam. They identify the sources of income gains or losses from further opening up to trade and show how these are distributed among countries or regions. The CGE models take into account that any policy targeted at one sector or group has indirect economic effects on the rest of the economy. Most models combine household data with industry data. The data allowing disaggregating at the household level is the Vietnam Living Standards Survey (VLSS). This survey was done for 1993, 1998, 2002, and in 2004. The VLSS contains a detailed breakdown of income sources and expenditure patterns for 6,000 surveyed households for the 1998 VLSS, while later versions include even more surveyed households. In term of industry data that used in most papers are the 1996 Input-Output (I-O) table, with indicators for 97 sectors, and the 2000 I-O table.

Abbott *et al.*, [89] study has reviewed Studies on the Social and Economic Impacts of Vietnam's International Economic Integration. The authors found that Most of CGE models for Vietnam until this time have concentration on trade liberalization. Since Vietnam on the way to join WTO and become official members in 2007 there have numerous studies conducted on Vietnam's integration process to try to infer some common patterns. They identified two groups of studies. One group relies on computable general equilibrium (CGE) models to simulate the economy-wide effects of changes in tariffs and subsidies. The second group of studies takes a partial approach.

Chan *et al.*, [90] model focus on evaluating tax reform in Vietnam, the study investigate the aggregate welfare impacts of sales tax reform alone compared to a scenario combining sales tax reform with tariff reform. They note that as a member of AFTA, Vietnam will have to reduce tariffs to below 5 percent by the year 2006. Tariffs account for one third of the budget revenue and joining AFTA with the accompanying tariff reductions will have negative effects on the budget revenue. The study analyzes the effects of covering this gap with sales tax reform. They use 1996 industry data and 1992-93 household data to predict the effects and apply the assumption about Armington differentiation between imports and domestic products.

Their model follows Dervis *et al.*, [91] and Devarajan and Lewis [92]. The SAM is composed from six accounts: factors (labour and capital), households (five household groups differing with respect to income), enterprises, Government, Rest of the World (ROW), activities (nine production sectors), domestic consumption and export, and capital account. All existing indirect taxes at final consumer demand level are replaced

by an equal-yield tax rate on all commodities except agriculture, with indirect tax rates endogenously determined so as to preserve the yield in the tax system. With respect to choosing the size of elasticities, Chan *et al.*, [90] note the lack of any estimates on elasticities of substitution in trade, consumption and production for the Vietnamese economy and argue that there is no possibility to conduct necessary surveys to estimate these. Therefore, they chose elasticity parameters from the central tendency values following Piggott and Whalley [93] and Shoven and Whalley [51] and from their assumptions after discussion with modellers from developing countries. In sum, their elasticity values range from 0.8 to 1.2.

Fukase *et al.*, [94] provide a quantitative evaluation of the United States granting Most Favored Nation (MFN) status to Vietnam. The model is the Hertel Global Trade Analysis (GTAP) model [95]. An important characteristic of the GTAP model is that it is disaggregated with respect to trading partners, where other studies rely on one aggregated block called 'Rest of the World'. The version used is GTAP 4. Documentation is provided in McDougall *et al.*, [96]. The base year for this data set is 1996. It is assumed that tariffs on Vietnamese exports to the US fall from an average of 35 percent to 4.9 percent. These were calculated using 1997 MFN rates weighted by Vietnamese export shares.

Fukase and Martin [97] provide a quantitative evaluation of Vietnam's accession to the ASEAN Free Trade Area. Five scenarios are differentiated with respect to the degree of discrimination and liberalization. The same model structure as the one used by Fukase *et al.*, [94] is used. Fukase and Martin [97] argue that unilateral liberalization has two offsetting effects on output levels. On the one hand, reductions in the costs of intermediate inputs create beneficial forward linkages to domestic production and promote industrialization, see Puga and Venables [98]. On the other hand, more intense import competition has an adverse effect on the profitability of import-competing firms.

Chan and Dung [99] analyze the impacts on the Vietnamese economy of a uniform reduction in tariffs on imported goods, combined with sales tax reform to maintain government revenue. The VAT is yield determined. Their SAM includes the structure of the 1996 I-O table and the 1998 VLSS. First, Chan and Dung (2001) compare two scenarios, both combined with sales tax reform: (i) reduction of all tariffs to 5 percent in 2003, and (ii) removal of all tariffs. Second, they run the simulations in scenario (i) again, relaxing the key assumptions to analyze the effect of these assumptions. Thus, scenario (iii) assumes that the ratio of consumption between imported and domestic goods is the same for all household groups.

There have been only few quantitative investigations of Vietnam's recent economic achievements. Hoang 2008 [100] presented a multi-sectoral dynamic CGE model to investigate the causes of country's recent performance. Their CGE model impose neo-classical economic structure, it carefully distinguish causes and effects, rapid growth in exports and change in export structure are largely endogenous.

Nguyen 2008 [101] study investigates economywide effects of international remittances on the source countries, where Vietnam is taken as a case study. The CGE modeling techniques investigate the effects of international remittances on the Vietnamese economy as a whole. Findings from the research strengthen the view that effects of remittances on developing countries are mixed and complicated. The results show that in the context of Vietnam, where the growing remittance inflows are combined with the economy's increasing integration into international markets, all factor prices tend to rise, and industrial sectors are strongly influenced and tend to contract. This implies that the long-run effects of remittances may be negative on the supply side, and may offset their short-run positive effects on the demand side.

2.5 Conclusion

CGE models are widely used in the quantitative evaluation of the economic effects of changes in various policies. The history of CGE modeling dates back to the 1980s. In general CGE models can be categorized into three generations. The first generation CGE models conform to the traditional neo-classic assumptions of perfect competition and market clearing. In contrast, the effects of imperfect competition and increasing returns to scale provide a new area for the development of the second generation models. Lastly, the third generation models focus on the dynamic impacts of policy changes.

The literature on CGE models in many countries and regions of East Asia is relatively recent and scarce when compared to those concerned with the North America and the European Union. The literature reviews in this chapter gives an overview of CGE modeling analysis which have been used to assess many economic policy issues in recent years and it could be the essential tool in the near future for estimating the economic effects of policy changes.

Chapter 3

Transportation Infrastructure Investment and Policy in Vietnam

3.1 General introduction

This chapter provides background on current status and trends of transportation infrastructure investment in Vietnam as well as the transport policy in the future. It summarizes the results of the effectiveness from transport investment projects over the country in recent years. Also describes the current status of Vietnam's transport policies implementation as well as methodologies for measuring the effects of the transportation infrastructure investments on the country's economy. The final part of this paper offers conclusions regarding the status of Vietnam's transport sector and policies and recommendations regarding modeling analysis for estimating the economics effects of transportation investment in the country.

Transport sector has contributed positively to the economic growth of the country over past decade and also plays an important role in poverty reduction of Vietnam. Together with the development of other sectors, transportation made significant process and basically met the demand for goods and passenger transport in the country and part of export and import transport.

3.2 Overview

The quality and efficiency of this infrastructure affects quality of life, the health of the social system, and the continuity of economic and business activity. The economic

strength of a country is reflected in its infrastructure asset. The history of economic and social system walks parallel with infrastructure development. Demands on infrastructure and related services increase as people expect a higher quality of life and public services. But, more importantly, good infrastructure facilitates a higher quality of life, Hudson *et. al.*, [102].

Vietnam is laid in a strategic location in Asia and it situated in one of the world's most dynamic transport nodes. The country holds the huge potential for development of transport networks and services for Vietnam to integrate into regional and international economy communities and improve Vietnamese transportation infrastructure's position in networks in Asia and the rest of the world. Vietnam is a developing country in Southeast Asia region, shares common borders with the People's Republic of China (PRC), Laos and Cambodia. Vietnam's total area of about 330,000 square kilometers (km²), of which has 50 percent is in productive use. The total land area, 21 percent or about 6.9 million ha, is used in agriculture and the remaining 9.8 million ha (29percent) are productive forest lands. The population of Vietnam in 2009 was 85.79 million. Vietnam became the third most populous country in Southeast Asia (after Indonesia and the Philippines) and the thirteenth most populous country in the world. The population in urban areas was 25.37 million, accounting for 29.6% of the total population, see GSO [103].

In Vietnam as well as in many countries transportation is an intermediate input, which helps to increase the productivity, economic growth, solve social problems such as poverty elimination and narrowing the gap between regions in order to achieve sustainable development. Transportation plays an important role in economic development through increasing productivity, providing necessity, and improving living standards. In point of view among the enterprises, transport system is very essential in their business activities. If the transportation system condition is good, they can have lower business costs, and allows access to production resources like capital, labor, materials and consuming market. Thus, the investors always consider about transportation as one of the most important factors when they choosing an investment location.

During 1999 and 2004, the demand for freight transport increased about 11 percent per annum in term of ton-km while the demand for passenger transport growth 9.4 percent per annum. Comparing the freight transport mode among sub-sectors, road is dominant mode which accounts for nearly 70 percent of tons moved but coastal shipping accounts for 72 percent of ton-km due to its dominant in long-distance transportation mode and remaining 28 percent was shared with railways, aviation and other modes, see Table 3.1.

TABLE 3.1: Volume of domestic freight and passenger transport, 1999-2004

Mode		1999				2004				Annual increase
Freight transport		1000 tons	%	mil ton-km	%	1000 tons	%	mil ton-km	%	
Railways		5,146	2.7	1,445.5	3.6	8,829.4	3.1	2,790.8	4.1	14.1
Roads		132,137.3	69.4	7,159.8	17.8	192,562.5	67.6	10,305.5	15.3	7.6
Inland-water ways		39,887.2	21	3,967.8	9.8	59,071.4	20.7	5,591.8	8.3	7.1
Maritime		13,006.1	6.8	27,619.6	68.5	24,363.6	8.6	48,335.9	71.9	11.8
Aviation		42.5	0.02	105.5	0.3	102.5	0.0	237.9	0.4	17.7
Total		190,219.1	100.0	40,298.2	100.0	284,929.4	100.0	67,261.9	100.0	10.8
Passenger transport		mil. pass	%	mil pass-km	%	mil. pass	%	mil. pass-km	%	Annual increase
Railways		9.3	1.3	2,722.0	8.8	12.8	1.1	4,378	9.0	10.0
Roads		588.4	81.0	22,053.3	71.3	999.7	84.4	31,730.7	65.4	7.5
Inland-water ways		125.7	17.3	2,109.7	6.8	166.2	14.0	3440.0	7.1	10.3
Aviation		2.7	0.4	4,042.0	13.1	5.6	0.5	8,948.0	18.5	17.2
Total		726.1	100.0	30,927.0	100.0	1,184.3	100.0	48,496.7	100.0	9.4

Note: Author calculated from GSO [103].

3.3 Vietnam's Transport Sector

Transportation plays an extremely important role in the socio-economic development of country's economy and Vietnam in particular is not an exception. Transportation infrastructure sector has been accorded the highest priority in the Vietnam's national development plan. The government's objective is to develop a modern transport system, which provides high quality, efficient and affordable transport services in a safe and environmentally sound manner according to MOT 2004 [104].

The positive impact of transport sector on economic development and poverty reduction has been widely realized by the Vietnamese government and the other enterprises. Transportation meets the demand for commodities and intermediate goods delivery to the firms and provides goods to the markets for consumption purposes. Passenger flows transportation meets the demand for travel of people and contributes significantly to their accessibility to workplaces and tourism service development. Transportation plays an important role in trade promotion for the country when commercial production is rapidly raised with huge volume of trade flows.

According to the Ministry of Finance (MOF), total nominal public expenditure in transport increased at almost 21 percent per annum between 1999 and 2002 reached 3.5 percent of GDP in 2002 versus an average of 2 percent in the late 1990s. Table 3.2 shows the proportion of the state budget directly allocated to the local government which has increased significantly from 44 percent in 1999 to 56 percent in 2002. However, the recurrent expenditure while having a large increase in 2000 has dropped back close to its 1999 level.

TABLE 3.2: Transport Sector Expenditure in Vietnam 1999-2002. *unit in billion VND*

	1999	2000	2001	2002	Annual growth%
Total Transportation Expenditure	10,616	11,375	14,985	18,721	20.8
- Total Exp. by Central Gov.	5,901	6,391	6,582	8,305	12.1
- Total Exp. by Local Gov.	4,715	4,984	8,403	10,416	30.2
Transport Exp. as % of GDP	2.7	2.6	3.1	3.5	NA
Transport Exp. as % of total Transport Exp.	12.5	11	12.5	13.8	NA
Local Exp. as % of total Transport Exp.	44.4	43.8	56.1	55.6	NA
Total Recurrent Expenditure	723	1,319	1,404	1,331	22.6
- Total Central Recurrent Exp.	331	792	799	580	20.6
- Total Local Recurrent Exp.	392	527	605	751	24.2
Recurrent Exp. as % of total Exp.	6.8	11.6	9.4	7.1	NA

Source: Ministry of Finance.

TABLE 3.3: GDP growth by sectors in Vietnam 2000-2008

	2000	2001	2002	2003	2004	2005	2006	2007	2008
Agriculture	10.07	10.39	9.48	10.48	10.22	10.69	10.38	10.6	6.33
Industry	4.63	2.98	4.17	3.62	4.36	4.02	3.69	3.4	3.79
Service	5.32	6.1	6.54	6.45	7.26	8.48	8.29	8.68	7.2
Total	6.79	6.89	7.08	7.34	7.79	8.44	8.23	8.48	6.23

Note: Author calculated from GSO data 2009 [103].

3.3.1 Key Drivers of Transport Sector

Since the comprehensive innovation policy "Renovation" was enacted, together with the development of other sectors, transport sector shown significant process and basically met the demand for commodities and passenger movement and trades. Viet Nam's economic growth rate increased every year in nearly a decade in 2000s, rising from 6.79 percent to 8.48 percent annually, kept the high growth rate even in the global economic downturn started from 2008, the GDP still at 6.23 percent. The Table.3.3 below present the growth rates by sector from 2000 to 2008 (the authors calculated from GSO 2009 [103]).

A long with the economic growth as noted above, transport demand in Vietnam is growing intensively. The average growth rate of good transport demand is about 7.3% per year between 1990 and 2030, according to the Transport Development Strategy of Vietnam up to 2020, the Ministry of Transport [105]. At the same period of time the demand for passenger transport is growing even faster by 12% per year. The rapidly increasing of transport demand leads to a good opportunity for development of transport service industries and also big challenges for capacity of both infrastructure and services. Fig.3.1 representing the growing of the transport demand in both freight transport

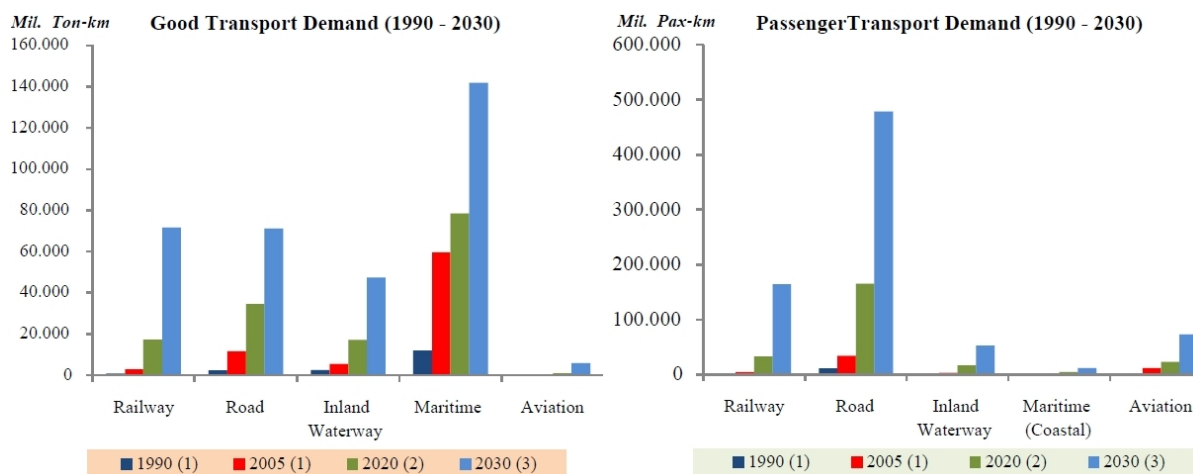

Source MOT 2007 [105].

FIGURE 3.1: The increasing of transport demand in both freight and passenger transport

TABLE 3.4: Population growing in Vietnam and its distribution, 2000-2008

	2000	2001	2002	2003	2004	2005	2006	2007	2008
Total population	77.63	78.62	79.54	80.47	81.44	82.39	83.31	84.22	85.12
Labor force	37.08	38.18	39.28	40.40	41.58	42.77	43.98	45.21	46.46
Structure of labor	48%	49%	49%	50%	51%	52%	53%	54%	55%
Transport labor	1.17			1.19	1.20	1.21	1.21	1.22	1.22
Structure	3.2%			3.0%	2.9%	2.8%	2.8%	2.7%	2.6%

Note: Author calculated from GSO data 2009 [103].

volume and passenger flows in Vietnam and also the trend for the next 20 years until 2030.

Population growth has been another key driver of increased transport demand in last decade. The sustain growth of population growth, accompanied by a considerable increase in the urbanization process, people are moving from rural areas to urban. The trends of overall population growth has shown in the Table. 3.4. During the period 2000-2008, total population growth in Viet Nam averaged 1.31 percent annually.

The Fig.3.2 shows the rapidly increasing of passenger traffic in Vietnam in over last decade. The volume of passenger traffic increased nearly four times within the period of time from 1995 to 2008 in which passenger volume travel by road has the most growth rate.

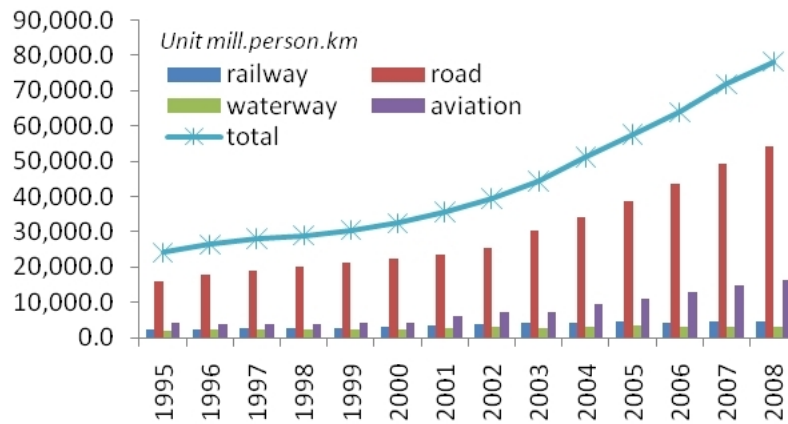

Note: Author calculated from GSO data 2009 [103].

FIGURE 3.2: Volume of passengers' traffic in Vietnam, 1995-2008

3.3.2 Current projection of transport investment

As presented in MOT 2007 [105], road infrastructure has been intensively focused during the last decade. The government invested on transportation as road-based development through the spending of central government on road counted about 90% of total transport expenditure. And the most of transportation infrastructure had been done by state-owned enterprises and because of inefficient management structure, mechanism as well as corruption which led to facing with serious problem of efficiency and debt. The expenditure process has been done through a closed and non-transparent system between government agencies and their son's contractors.

The rapidly growing of transport demand put Vietnam under high pressure on transportation infrastructure investment. According to statistic from GSO the percentage of paved national road has been increased from 60% in 1995 to about 92,5% in 2006 and the country has achieved increasing of road network about 151.632 km in which 42.5% have asphaltic or concrete pavement, GSO [103]. In railway, port, and waterway have been obtained remarkable achievement to meet the transport demand. However, it is lacking of high-speed road and high-speed railway transport routes. Fig.3.3 represented the strategic transport networks in Vietnam.

Ministry of Transportation and Communication has submitted he Vietnam Transport Development Plan up to 2020 to the Prime Minister on December 2002 estimated the average investment demand between 2002 and 2020 at \$US 7 billion per year, with almost 60 percent of that budget allocated for rail way and urban transportation.

It is 6 times over the transport expenditures in 2002 and would account for about 14 percent of GDP of the year 2005. The total expenditure estimated by the MOT is

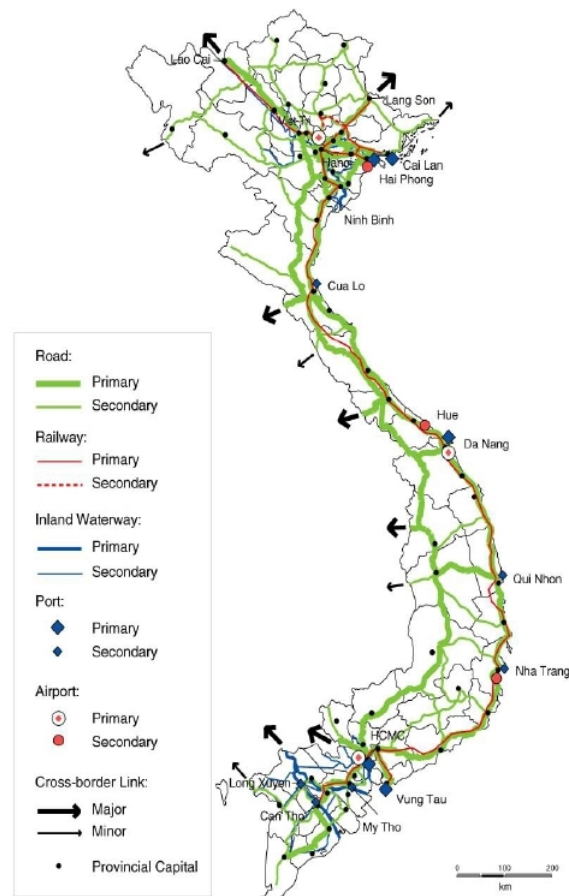

Source MOT 2007 [105].

FIGURE 3.3: The strategic transport networks in Vietnam.

five times higher than the investment requirements proposed by the VITRANSS3 and includes additional expenditure for urban transport, local transport, expressways and railways. According to the VITRANSS, the total budget investment up to 2010 is estimated about \$US 11.5 billion which excludes the investment for expressways, ports and urban transport, see Table. 3.5

3.3.3 Efficiency of Transportation Investment in Vietnam

In this part we summarize the methodologies which have been using to estimate the affect of transportation infrastructure investment in Vietnam. Even though, transportation plays an essential role in socio-economic and security of the country. In context of economic integration since Vietnam become official members of WTO, the country has to comprehensively improve its transportation system, in which the transportation network for socio-economic development and for commodity transport and public transport should be the core, however, there are few research pay concentration on this field.

TABLE 3.5: Investment Demand for Transport Infrastructure

	2002-2010	2011-2020	2002-2020	Annual average
Total	50,125	84,352	134,477	7,078
Road (includes)	15,609	20,846	36,454	1,919
- <i>Expressway</i>	<i>3,589</i>	<i>10,059</i>	<i>13,648</i>	<i>718</i>
- <i>National Highways</i>	<i>8,846</i>	<i>7,931</i>	<i>16,778</i>	<i>883</i>
- <i>Provincial Road</i>	<i>3,173</i>	<i>2,855</i>	<i>6,028</i>	<i>317</i>
Rural Transport	5,489	4,940	10,428	549
Railway (includes)	13,874	24,973	38,848	2,045
- <i>Express Railway</i>	<i>12,944</i>	<i>22,938</i>	<i>35,882</i>	<i>1889</i>
- <i>Normal Railway</i>	<i>930</i>	<i>2,035</i>	<i>2,966</i>	<i>156</i>
Maritime	1,294	4,124	5,418	285
Inland Waterways	297	286	582	31
Civil Aviation	1,135	2,305	3,440	181
Urban Transport (in Hanoi and HCMC)	12,429	26,878	39,307	2,069

Source: Vietnam Transport Development Strategy up to 2020 (Ministry of Transport, 2002).

Mitsui [106] and Tho *et al.*, [107] have made a analysis on impact assessment of large scale transport infrastructure in Northern Vietnam, particularly focus on the Highway No. 5, in which the changing of the economic, living standard within the Red Delta Regions after the transportation infrastructure investment was implemented. The author found that the transport infrastructure projects in the Northern Vietnam made a great contribution to poverty reduction widely seen in the areas along the highway. The projects shed light on a wide range of roles of infrastructure as a prerequisite for economic growth and a direct contributor to poverty reduction, through multiple channels such as those identified in the projects. The analysis of this case has brought us to the important lesson that it is necessary to combine large-scale infrastructure projects with institutional support backed by the government's clear commitment in order to scale up the effect of poverty reduction.

The enlargement of the highway no.5 in particular the former is beginning to exert both direct and indirect large impact upon the agricultural and rural economic development of the part of, not whole of Red River Delta region that is second to the southern Mekong River Delta as a grain store region but also for neighboring regions located along the highway, the rapid progress in the structural change of specific sectors and expansion of a new economic activity are conspicuous.

There are some previous studies have focused on specific transportation projects, those models have adopted a broader methodological framework to understand the linkages between public investment, growth and poverty reduction, such as on the MyThuan Bridge in the Mekong river delta region AusAIDS [108], the sectoral reviews as the case of the transport sector in study of Vu and Aldas [109]. Fan *et al.*, [110] conducted study in

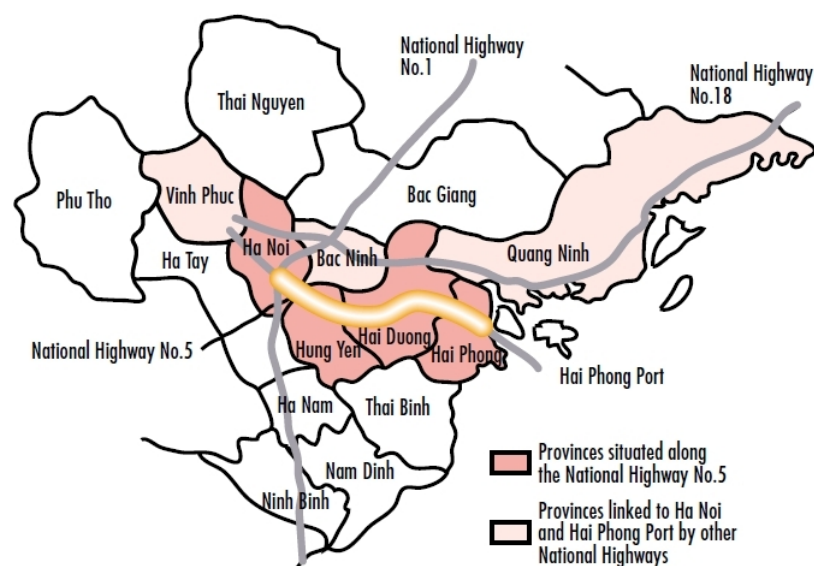

Source Tho et al., [107].

FIGURE 3.4: The Enlargement of Transportation in Red Delta Region.

which affects of infrastructure investment on road, electricity, telephone, agricultural RD and irrigation with respect to agricultural growth and poverty reduction. In 2004, study of Rama *et al.*, [111] assessed the poverty impacts of public investment employing three aspects: (i) a macroeconomic perspective, investment rate, and elasticity of poverty reduction to economic growth; (ii) provincial perspectives; and (iii) individual project approach.

Those studies above are comprehensive on illustrating a wide range of analytical approaches for assessing impacts of public investment on poverty. However, there have no one consider about spillover effects of the infrastructure investment.

3.3.4 Availability of Vietnam's Transportation Data

After several decades implementing planned economy, statistic data of several sectors including transport sector, in some ways that has been relatively collected. One representative statistical data source is Statistical Yearbook, which is yearly published by the General Statistical Office, another one made by governmental organization which collecting several data at the national level as well as conducting household surveys or population surveys. In which we can observe total traffic volume at national level of passenger transport and freight transport, on sub-sectors such as road, railway, maritime, inland waterway and airway. However, freight volume by TEU is not shown in the Statistical Yearbook, the origin-destination transport data is not available in Vietnam.

3.3.5 Transportation Policy of Vietnam

The 2004 Transport Sector Development Strategy (TSDS) to 2020 supports Vietnam's various economic development plans, notably, the ten year (2001-2010) Socio Economic Development Strategy and the Comprehensive Poverty Reduction and Growth Strategy [112]. The first one identifies the upgrading of Highway No.1 as the first priorities and strongly endorses the development of public transport services and long term regional transport planning, and also cites the rising rate of traffic accidents as a concern, as well as emphasis and priorities differ within Vietnam's 8 regions. The main elements of TSDS are:

A balanced approach to transport development capitalizing on the country's geographical shape; Prioritization of maintenance and upgrading of existing assets; Prioritization of rural transport infrastructure especially in mountainous and remote regions; Prioritization of new investments in the north-south backbone, important economic zones, large urban areas and key links to neighboring countries; Prioritization mass transit systems in the urban sector; Increasing the local content in ship and automobile construction and repair; Increasing the share of domestic enterprises in the international transportation of Vietnamese goods.

TSDS highlights several policies to govern implementation, include (i) targeting domestic and foreign sources of finance, both private and public, and charging users for the construction and maintenance of infrastructure when possible; (ii) encouraging private sector participation by speeding up the equitization of state-owned enterprises and separating state management from operations and business; (iii) ensuring transport safety and environmental protection in transport related activities, utilizing new technologies and processes in transport-related construction and operations.

3.4 Summary and Recommendations

There has very important aspect of infrastructure transportation construction; the structure of many types of infrastructure might imply that there are benefits to individual beyond the region or locality where the infrastructure is located. On the other hand, better infrastructure in one region could assist firms in neighboring regions with drawing away the most productive resources, which could be detrimental to firms in the locality with enhanced infrastructure. In order to have effectiveness of evaluation, a type of CGE models should appropriate be applied to estimate the effects of highway infrastructure investment projects on the economics of the region.

Chapter 4

Input-Output Table Analysis

4.1 General introduction

This chapter describes about data base preparation for the research. The characteristics and development of Vietnamese economic data are mentioned. The chapter mainly focuses on input-output table data of Vietnam after overview input-output systems in general.

To produce output, sectors require each other's inputs. The economy is classified by sectors, the sectors may have a variety of commodities as inputs and their outputs are not mixed. Each sector is identified with the commodity that it produces. The core of Input-Output analysis is a matrix of technical coefficients that summarizes the interdependencies between the sectors of production. Input-output (IO) model uses a matrix represents an economy to predict the effect of changes in one industry on others of the economy. It is very helpful in policy-making process. IO analysis is a methodology named for modeling framework developed by Wassily Leontief for work he undertook in the 1930s [113] [114].

During the last decades, there have numbers of studies on extending IO model and there are different ways to develop input-output framework initiated by W. Leontief. Including the Social Accounting Matrix (SAM) extended by Richard Stone [115], the Inter-regional input output framework developed by Miyazawa [116].

4.2 Vietnamese National Account

Since Doi Moi process of Vietnam 1986 has moved the country into market economy, the General Statistics Office (GSO) changed the framework of compiling the country's accounts from the Material Product System (MPS) to the System of National Accounts (SNA). The GSO through its System of National Accounts Department (SNA) started compiling the country's annual national accounts based on the SNA in the early 1990s.

Until 1988, national accounts were calculated using the Net MPS. Since 1989, the country adopted the System of National Accounts (SNA) and has calculated GDP in 1989 market prices beginning with data for 1988. After success from adopting SNA, the government legislated SNA through whole the country replaced MPS from 1992. The first IO table of Vietnam with size of 54 sectors has made for 1989 by GSO. IO table for 1996 with 97 sectors; IO table for 2000 with 112 sectors; IO table for 2005 with 112 sectors which is converted to SAM; Latest version of IO table for 2007 with 138 sectors; Interregional IO tables which were made by organizations from oversea countries.

4.3 Vietnam Input-Output Table

Currently, the national IO table is of the competitive-imports type wherein no distinction is made between local and imported inputs. In System National Accounting includes two types of IO tables: competitive-imports IO table and non-competitive IO table. In developed countries non-competitive IO table has established based on survey, which is important to adjust the export and import index of the economy. However, Vietnam through its GSO has only launched official IO table as competitive-import caused by difficulties have been met during data collection and knowledge in implementing IO analysis is not sufficient. The development of SNA for Vietnam can be presented in the table below:

In System National Accounting includes two types of IO tables: competitive-imports IO table and non-competitive IO table. In developed countries non-competitive IO table has established based on survey, which is important to adjust the export and import index of the economy. However, Vietnam through its GSO has only launched official IO table as competitive-import caused by difficulties have been met during data collection and knowledge in implementing IO analysis is not sufficient.

TABLE 4.1: Development of National Accounts and IO Compilation in Vietnam

Type of Economic Account	Start of Compilation Based on SNA	Frequency of Compilation	Compiler
National Accounts	—	—	—
Annual	1992 (UNDP sponsored)	annual	SNA/GSO
Quarterly	1998	quarterly	SNA/GSO
Regional GDP	1993	annual	SNA/GSO
National IO tables	—	—	—
Benchmark	1989	1996, 2000	SNA/GSO
I/O Update	1990	annual	SNA/GSO
Regional IO tables	—	—	—
Ho Chi Minh	1996	2000	Economic Institute of HCM, PSO
Red River Delta Region	1996	one time	LOICZ Project
Interregional IO tables	—	—	—
Ho Chi Minh City - The rest of Vietnam	1996	—	Private researcher group
Danang - Ho Chi Minh - The rest of Vietnam	2005	—	AREES
Multi-region Inter-Regional I/O Framework for Vietnam	2008	—	AREES, GSO

Note: Author adapted from Bui *et al.* [117] [87].

TABLE 4.2: Framework for competition-imports IO table.

Sectors	Intermediate demand			Final demand						GO
	1	2	3	C	G	I	E	-M	Import Tax	
1	X_{11}	X_{12}	X_{13}	C_1	G_1	I_1	E_1	$-M_1$	T_1	X_1
2	X_{21}	X_{22}	X_{23}	C_2	G_2	I_2	E_2	$-M_2$	T_2	X_2
3	X_{31}	X_{32}	X_{33}	C_3	G_3	I_3	E_3	$-M_3$	T_3	X_3
VA	V_1	V_2	V_3							
GI	X_1	X_2	X_3							

Note: Adapted from Bui 2010, Input-Output Analysis textbook, in Vietnamese.

4.3.1 Competitive Imports IO Table

The national IO table is of the competitive-imports type wherein no distinction is made between local and imported inputs. In this IO table, intermediate demand and final demand include import and import tax as showed in the Table 4.2.

Notation:

- X_{ij} intermediate input of i used for production of j
- C_i final demand of household for good i
- G_i final demand of government for good i

- E_i export of good i
- M_i imported good i
- T_i import tax of good i
- V_j value added of sector j
- X_i total output of sector i

Basic relationships

- $X_{i1} + X_{i2} + X_{i3} = IC_i$ is the total intermediate demand of i
- $X_{1i} + X_{2i} + X_{3i} = II_i$ is the expenditure intermediate of i
- $Y_i = C_i + G_i + I_i + E_i - M_i$ is the expenditure final demand of i
- $IC_i \neq II_i$ however $\sum IC_i = \sum II_i$

Input coefficient $A_{ij} = X_{ij}/X_j$

And the relationship equation yielded as follow:

$$A_{i1}X_1 + A_{i2}X_2 + A_{i3}X_3 + Y_i = X_i \quad (4.1)$$

This can be written in matrix form:

$$A.X + Y = X \quad (4.2)$$

$$X = (I - A)^{-1}.Y \quad (4.3)$$

This is called Leontief's inverse matrix. It presents spillover effect of unit final demand change on other sectors in the economy.

4.3.2 Non-competitive Imports IO Table

In the non-competitive imports type IO table, intermediate demand and final demand have been separated into domestic output. Two columns of import and import tax are eliminated and two rows of import and import taxes have been extracted. IO analysis yields more meaningful results by using the non-competitive type.

Notation:

- X_{ij}^d domestic-produced of i used for production of j
- C_i^d final demand of household for domestic-produced of good i

TABLE 4.3: Framework for non-competition imports IO table.

Sectors	Intermediate demand			Final demand				GO
	1	2	3	C	G	I	E	
1	X_{11}^d	X_{12}^d	X_{13}^d	C_1^d	G_1^d	I_1^d	E_1	X_1
2	X_{21}^d	X_{22}^d	X_{23}^d	C_2^d	G_2^d	I_2^d	E_2	X_2
3	X_{31}^d	X_{32}^d	X_{33}^d	C_3^d	G_3^d	I_3^d	E_3	X_3
Import	M_1^p	M_2^p	M_3^p	M_c	M_g	M_I		M
Import tax	T_1^p	T_2^p	T_3^p	T_c	T_g	T_I		T
VA	V_1	V_2	V_3					
GI	X_1	X_2	X_3					

Note: Adapted from Bui 2010, Input-Output Analysis textbook, in Vietnamese.

- G_i^d final demand of government for domestic-produced of good i
- I_i^d inventory domestic-produced of good i
- E_i export of good i
- M_i^p imported intermediate good for production of i
- M_c total imported goods for households final consumption
- M_g total imported goods for government final consumption
- T_i^p, T_c, T_g, T_I Taxes

Basic relationships

And the relationship in Equation 4.1 can be expressed as follow:

$$(A^d + A^m)X + Y^d + Y^m - M = X \quad (4.4)$$

Rewrite:

$$A^d X + Y^d + A^m X + Y^m - M = X \quad (4.5)$$

$$A^m X + Y^m = M \quad (4.6)$$

Then Equation 4.2 can be rewritten as follow :

$$A^d X + Y^d = X \quad (4.7)$$

It becomes the following equation:

$$X = (I - A^d)^{-1} Y^d \quad (4.8)$$

This becomes Leontief's inverse matrix. It is better to present forward linkages and backward linkages in the economy. Thanks to this matrix, policy maker can propose

stimulate plan in the key sectors for whole economy.

4.3.3 Basic Principle of IO Table

4.3.3.1 Output

There are three types of price for the output:

- Basic's price
- Producer's price
- Purchaser's price

The relationship among them can be presented as follow:

- Basic's price + Tax = Producer's price
- Producer's price + transportation cost + trade = Purchaser's price

In service sectors, the producer's price and purchaser's price are equaled because the products are consumed directly without any transaction.

4.3.3.2 Data collection methodology

In principle, output of the sectors is counted by multiplying quantity and price. In Vietnam, however, collected data is calculated as follow total gross supply methodology. The data collected from the firms and particular show below:

1. Agriculture sectors: quantity multiply by purchaser's price
2. Manufacturing: basic's price = net revenue + (variance of finished product and unfinished product of whole cycle) – transport cost
3. Construction sectors: basic's price= net revenue + (variance between ending and beginning cycle for unfinished products)
4. Trade, electricity, real-estate: basic's price = net revenue – value of sell products
5. Hotel, restaurant: basic's price = net revenue –value of sell products
6. Service sectors: basic's price = net revenue

4.4 Interregional IO Table for Vietnam (IRIO)

Inter-regional input output models have been applied in many empirical studies to address a wide range of policy issues and to analyze their impacts on other regions. For example, the benchmark report of State of Hawaii [118] applied a multi inter-county input output model in order to analyze the economic impacts between counties of Hawaii State.

In the development of more general or economy-wide models, the initial addition to standard input-output systems has been viewed as the social accounting matrix most closely associated with Richard Stone. A parallel development was proposed and empirically implemented by Miyazawa [119]; however, these contributions were not widely appreciated outside Japan until Miyazawa brought them to the attention of modelers on regional science in 1976. Miyazawa's major contributions are the notions of internal and external multipliers, which can be used to explain the role of interregional trade and interrelation between income and consumption [120].

Isard [63] develops an advanced IO analysis which is extended from the work of Leontief to analyze IO tables at the subnational level on the theoretical structure of interregional IO tables under the assumption that the sectoral and geographical origin of each delivery can be specified. In 1972, thanks to this study, Richardson [121] developed a model describes the identical sectors in different regions are treated as distinctly separate industries then interregional trade flows by regions of origin and destination and by industry of source and purchasing sector are full specified. Rising a problem about detailed level of disaggregation data are mostly not available due to the time and financial constraints to conduct data collection then this type of study has rarely been taken implemented empirically in entirety.

Hence, to reduce the time resources and financial matter, a hybrid approach to constructing IRIO tables has been utilized. The Chenery-Moses model has been developed with less data requirement. This essentially involves conducting surveys to collect the necessary data for the most important sectors of the economies concerned and using various non-survey methods to obtain the estimates for the other sectors. Since then, many studies have been built on IO table at interregional level.

In Europe number of IRIO tables have been developed such as Fritz *et al.*, [122] developed IRIO table for Austria, Verdura for Spain [123]. In Asia, various separate studies have been conducted recently to develop IRIO tables for countries such as works of Ishikawa and Miyagi [124] for Japan, Okamoto [125] for People's Republic of China, Secretario [126] for Philippines, for Vietnam by Secretario [127], Bui *et al.*, [86] applied

	to	Intermediate demand		Final demand				Output
		Region s		Region s		ROW		
from		1..j..n	T	1..j..n	T	E	M	
Region r	1							$X_i^{*,r}$
	.							
	i	$X_{ij}^{*,rs}$		${}^D Y_{ik}^{*,rs}$		$E_i^{*,rw}$	0	
	.							
	n							
	T	$X_{Tj}^{*,rs}$	$X_{TT}^{*,rs}$		$X_{TT}^{*,rs}$			
ROW	1							0
	.							
	i	$X_{ij}^{*,ws}$		${}^D Y_{ik}^{*,ws}$		0	M_i	
	.							
	n							
	T	$X_{Tj}^{*,ws}$	$X_{TT}^{*,ws}$		$X_{TT}^{*,ws}$			
GVA	1							GDP
	2							
	.	$V_{pj}^{*,vs}$		0		0	CDT	
	.							
	n							
Total gross input		$X_j^{*,s}$	$T^{*,s}$	$\sum {}^D Y^*$		$\sum E^*$	$\sum M^*$	

FIGURE 4.1: Framework of IRIO table for Vietnam. Note: subscripts (*) indicate that the value represented in original IRIO table

a multi inter-regional input output model for 7 regions of Vietnam in order to estimate impacts of income between regions.

4.4.1 Construction of IRIO

Basic relationships in interregional IO model show as follow. The framework of IRIO table for Vietnam as presents follows the Fig.4.1. Adapted from Bui *et al.*, [86].

Notation of IRIO framework for Vietnam

- $X_{ij}^{*,rs}$ total output of i produced in region r and used in region s
- $X_{ij}^{*,ws}$ imported intermediate inputs of goods i from sector j in region s

- V_{pj}^{vs} value added of sector j in region s
- Y_{ik}^{rs} final demand of goods i in region s produced in region r
- Y_{ik}^{ws} final demand of imported good i in region s
- E_i^{rw} output of export goods of region r
- M_i imported goods of region r
- X_i^r output product of regions r
- X_j^s total input of regions s
- CDT custom duties and taxes paid for import, in negative sign

Total value added equal to final demand of the region

$$\sum V_{pj}^s + CDT = \sum [{}^D Y_{ij}^{rs} + E_i^{rw} + {}^D Y_{ik}^{ws} + (M_i) + CDT] \quad (4.9)$$

Interregional equilibrium condition has form

$$X_i^r = X_{ij}^{rs} + {}^D Y_{ik}^{rs} + E_i^{rw} \quad (4.10)$$

$$r = s = 1, \dots, 3; i = j = 1, \dots, 4; k = 1, \dots, 3$$

Or

$$X_i^{R1} = [X_{ij}^{R1S1} + X_{ij}^{R1S2} + X_{ij}^{R1S3}] + Y_{ik}^{R1S} + E_i^{R1W} \quad (4.11)$$

$$X_i^{R2} = [X_{ij}^{R2S1} + X_{ij}^{R2S2} + X_{ij}^{R2S3}] + Y_{ik}^{R2S} + E_i^{R2W} \quad (4.12)$$

$$X_i^{R3} = [X_{ij}^{R3S1} + X_{ij}^{R3S2} + X_{ij}^{R3Sm}] + Y_{ik}^{R3S} + E_i^{R3W} \quad (4.13)$$

$$a_{ij} = X_{ij}/X_j$$

Assuming a country divided into three regions

$$(a1-1) a_{ij}^{R1S1} = X_{ij}^{R1S1}/X_j^{S1}, (a2-1)a_{ij}^{R2S1} = X_{ij}^{R2S1}/X_j^{S1}, (a3-1)a_{ij}^{R3S1} = X_{ij}^{R3S1}/X_j^{S1}$$

$$(a1-2) a_{ij}^{R1S2} = X_{ij}^{R1S2}/X_j^{S2}, (a2-2)a_{ij}^{R2S2} = X_{ij}^{R2S2}/X_j^{S2}, (a3-2)a_{ij}^{R3S2} = X_{ij}^{R3S2}/X_j^{S2}$$

$$(a1-3) a_{ij}^{R1S3} = X_{ij}^{R1S3}/X_j^{S3}, (a2-3)a_{ij}^{R2S3} = X_{ij}^{R2S3}/X_j^{S3}, (a3-3)a_{ij}^{R3S3} = X_{ij}^{R3S3}/X_j^{S3},$$

Equations (a1-1), (a2-2), and (a3-3) present coefficient of intermediate input within the one region, and the coefficients of intermediate input for domestic are show in the

equations below:

$$X_i^{R1} = [a_{ij}^{R1S1} X_j^{S1} + a_{ij}^{R1S2} X_j^{S2} + a_{ij}^{R1S3} X_j^{S3}] + Y_i^{R1} + E_i^{R1W} \quad (4.14)$$

$$X_i^{R2} = [a_{ij}^{R2S1} X_j^{S1} + a_{ij}^{R2S2} X_j^{S2} + a_{ij}^{R2S3} X_j^{S3}] + Y_i^{R2} + E_i^{R2W} \quad (4.15)$$

$$X_i^{R3} = [a_{ij}^{R3S1} X_j^{S1} + a_{ij}^{R3S2} X_j^{S2} + a_{ij}^{R3S3} X_j^{S3}] + Y_i^{R3} + E_i^{R3W} \quad (4.16)$$

Rewrite in matrix form:

$$\begin{bmatrix} X_i^{R1} \\ X_i^{R2} \\ X_i^{R3} \end{bmatrix} = \begin{bmatrix} a_{ij}^{R1S1} + a_{ij}^{R1S2} + a_{ij}^{R1S3} \\ a_{ij}^{R2S1} + a_{ij}^{R2S2} + a_{ij}^{R2S3} \\ a_{ij}^{R3S1} + a_{ij}^{R3S2} + a_{ij}^{R3S3} \end{bmatrix} \times \begin{bmatrix} X_j^{S1} \\ X_j^{S2} \\ X_j^{S3} \end{bmatrix} + \begin{bmatrix} Y_i^{R1} \\ Y_i^{R2} \\ Y_i^{R3} \end{bmatrix} + \begin{bmatrix} E_i^{R1W} \\ E_i^{R2W} \\ E_i^{R3W} \end{bmatrix} \quad (4.17)$$

And $X = AX + Y + E$

or $X = AX + [Y+E]$ or $X = (I-A)^{-1} [Y+E]$

As in national IO model, the basic relationship in intra-regional I-O model as formed:

$$AX + Y = X \quad (4.18)$$

or

$$(I - A) X = Y \quad (4.19)$$

Assume that the country is divided into three regions; the direct coefficient can be presented as follow:

$$A = \begin{pmatrix} A_{11} & A_{12} & A_{13} \\ A_{21} & A_{22} & A_{23} \\ A_{31} & A_{32} & A_{33} \end{pmatrix} \quad (4.20)$$

where

A_{11}, A_{22}, A_{33} are the quadrate matrices of direct inputs within region 1,2, and 3 respectively and the others $A_{ij}(i \neq j | i, j = 1, 2, 3)$ are the interregional matrices representing direct inputs connections from one region to another region.

X_i is the output of region i Y_i is the final demand of region i

$$X = \begin{pmatrix} X_1 \\ X_2 \\ X_3 \end{pmatrix} \& Y = \begin{pmatrix} Y_1 \\ Y_2 \\ Y_3 \end{pmatrix} \quad (4.21)$$

From Eq.4.19 yields:

$$\begin{pmatrix} I - A_{11} & -A_{12} & -A_{13} \\ -A_{21} & I - A_{22} & -A_{23} \\ -A_{31} & -A_{32} & I - A_{33} \end{pmatrix} \times \begin{pmatrix} X_1 \\ X_2 \\ X_3 \end{pmatrix} = \begin{pmatrix} Y_1 \\ Y_2 \\ Y_3 \end{pmatrix}, \quad (4.22)$$

Eq. 4.20 can be rewritten in the form:

$$(I - A_{11}) X_1 - A_{12} X_2 - A_{13} X_3 = Y_1, \quad (4.23)$$

$$(I - A_{22}) X_2 - A_{21} X_1 - A_{23} X_3 = Y_2, \quad (4.24)$$

$$(I - A_{33}) X_3 - A_{32} X_2 - A_{31} X_1 = Y_3, \quad (4.25)$$

Relationship between 3 regions can be presented by:

$$X_1 = (I - A_{11})^{-1} (A_{12} X_2 + A_{13} X_3), \quad (4.26)$$

$$X_2 = (I - A_{22})^{-1} (A_{21} X_1 + A_{23} X_3), \quad (4.27)$$

$$X_3 = (I - A_{33})^{-1} (A_{32} X_2 + A_{31} X_1), \quad (4.28)$$

Fig.4.2 shows the spillover and feedback effects in the regions model of Vietnam. Adapted from Bui *et al.*, [86]

4.5 Transportation Satellite Accounts

4.5.1 Introduction

In Vietnam, transportation plays an extremely important role in the socio-economic development. Transportation meets the demand for commodity freight of intermediate goods, and delivery goods to consumers and passenger movement transportation to meet the demand for travel of people. Recently, the country obtained remarkable economic

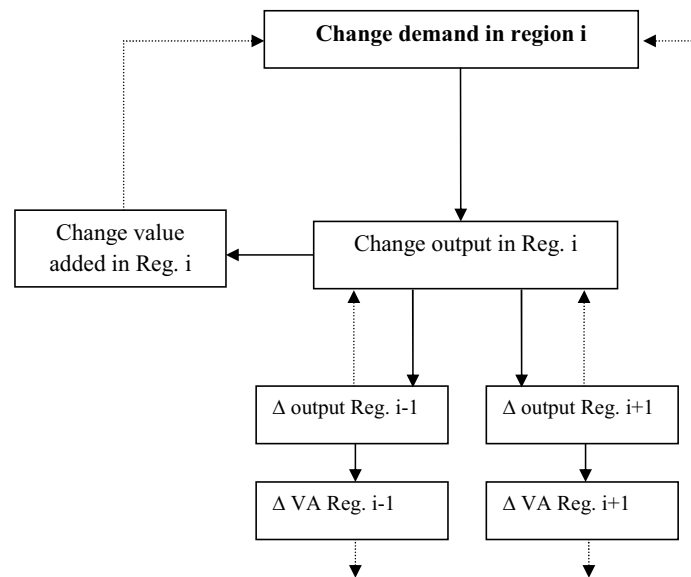

Spillover and feedback effects in the regions model of Vietnam

—▶ Direct and indirect effects
▶ Spillover effect

Source Bui *et al.*, [86]

FIGURE 4.2: The spillover and feedback effects in the regions model of Vietnam

achievements with commercial production is developed, with large volume of exports and imports, transportation plays an important role in trade promotion for the country.

Vietnam's transport sector has made good progress over the last decade in responding to the demand of rapid economic growth and the need to connect the most remote communes. According to Ministry of Finance, over the last decade, the Vietnamese government invested 1.8-2.5 percent of GDP in transport development which is mainly contributed by the state budget and ODA funds. This investment has helped the country to obtain GDP growth rate of 7.2 percent per annum.

4.5.2 Transportation Data Availability

Since the *Renovation* policy was enacted in 1986 transportation made significant process and basically met the demand for freight and passenger transport. After several decades implementing planned economy, statistic data of several sectors including transport sector has been relatively collected. One representative statistical data source is Statistical Yearbook, which is yearly published by the General Statistical Office (GSO), and another one governmental organization which collecting several data at the national level as well as conducting household surveys or population surveys. The total

traffic volume of passenger transport and freight transport at national level such as road, railway, maritime, inland waterway and airway can be found in the year book.

However, until now, national measures of transportation services still lack of origin-destination (OD) survey and data base. As stated above, it easy to observe the data on passenger and freight volume because they are relatively well collected in each terminals of bus, port and airport terminal. The first National Transport Development Strategy has been carried out in 1999-2000 with assistance from JICA which is made by combining the existing data and road side interview survey. The study served as a basis for working out the transport system development strategy toward 2020 and the development plan of the transport system to 2020. After that, the country has experienced significant economic development and a strong increase in the demand for passenger and freight transport. The integration into the global economy will diversify the potential of freight transportation between the country and others. However, the basic OD survey has not conducted due to lacking of network flow analysis skills budget and the country has no feasible plan for transportation sector development.

In the current IO table and IRIO table of Vietnam, is lacking of transportation services data of both the value of commercial- transportation and self-transportation services. Commercial-transportation services are provided by transportation firms to industries. The sizable contribution of self-transportation (transportation services that take place within non-transportation sectors) was not explicitly identified. Hence, the transport satellite accounts (TSA) for Vietnam is needed, it promise a relatively new tool to measure and analyse the transport sector as a whole. Satellite accounts provide an accounting framework linked to the national accounts and which enable attention to be focused on a certain field or aspect of economic.

4.5.3 Objective of TSA

We adopted transportation satellite accounts of Bureau of Transportation Statistics, US Department of Transportation [15] for estimating the size and role of transportation in the economy. This new accounting tool provides a way to measure both self-transportation and commercial-transportation services. The TSA reveal several important features concerning the relationship between transportation and the economy. A key concern addressed by the TSA is credibility of transport estimates.

Since both self-transportation and commercial-transportation services are not identified as a separate activity in the Input-output table and IRIO table. These tables provide details estimation of intermediate inputs purchases by firms including commercial-transportation service sectors, and then we can use to prepare the TSA estimates. The objective of a TSA is to bring together the information by essentially re-organizing the national accounts and supplementing them with additional concepts and data, and thus develop relatively credible quantification of different aspects of transportation.

Jari [128] has shown that TSA has a potential to provide an overarching framework for the development of integrated statistics on transport and help to ensure consistency between data sets, over time and possibly within and between nations. Statistics on transport can be organized in many ways depending on how they are to be used. For example, statistics may be produced according to the type of transport service provided - freight for goods, passenger for people, and other transport services needed to support transport system infrastructure.

A TSA therefore presents drawing together transport value and volume data into a single accounting framework. For our purpose using data in CGE model the benefits of compiling a transport satellite account include:

- Enabling estimates of the contribution of total transport activity in the economy, including transport services provided in-house by businesses where transport is not their primary activity;
- Identifying products and services which are characteristic or connected to transportation (and which industries supply and use these).
- Providing data by presenting detailed transport supply and use of products by sector (e.g. business, government, households) and mode of transport;
- Incorporating both volume (e.g. employment, freight movement data) and value data;
- Providing a range of data which will also ensure improvements to the quality of transport data feeding into the system of national accounts, including the input-output tables.

4.5.4 Relationship of TSA with National Accounts

4.5.4.1 The System of National Accounts

Satellite Accounts originated from the System of National Accounts (SNA), which is a set of guidelines for organizing information about the economy in a useful way. The SNA provides concepts, definitions, classifications and accounting rules to provide a comprehensive framework for analyzing production, investment, income and stocks and flows of financial and non-financial assets in the economy. For the purposes of the SNA, the economy is divided into institutional units which are economic units capable of owning assets, incurring liabilities on their own behalf and are centers of decision making for all aspects of economic life.

The production account emphasizes value added as one of the main balancing items in the system. Consequently, it does not cover all transactions linked with production but only the result of production (i.e., output) and the using up of goods and services in the production of the output (intermediate consumption). Intermediate consumption does not cover the progressive wear and tear of fixed capital, which is recorded as a separate transaction.

The distribution of income account looks at primary distribution of value added to factors of production (labour and capital) and to government through taxes less subsidies. It also looks at secondary distribution and redistribution in kind.

4.5.4.2 Relationship of the TSA to the IO table

The IO table provides detailed estimates of intermediate purchases by industries, including commercial-transportation and self-transportation industries; this detailed information can be used to prepare the TSAs estimates. The IO accounts also provide an analytical framework with detailed linkages among and between industries and final demand; this framework facilitates the estimates of the interdependencies between transportation and the rest of the economy.

The TSAs used the following IO account approaches:

- The measurement used to determine the value of self-transportation activities is similar to that used for self-construction activities in the I-O accounts. For example, the intermediate inputs and the value-added inputs associated with self-construction, such as capital consumption allowance and labor costs, are moved -

or, using I-O terminology, "redefined" to the other industries in which the activities are primary. In the TSAs, these inputs are similarly redefined, but to a newly defined industry, self-transportation;

- The overall industry and commodity classification system and the special definitions and conventions in the IO accounts are used in the TSAs except for self-transportation, which forms a new industry and a new commodity category in the TSA;
- The total value-added (or GDP) by all industries is the same in the TSAs and the IO accounts;
- The general valuation conventions used in the TSAs are consistent with those in the IO accounts: all transactions are valued in producers' prices, the valuations of purchases for final use are unchanged, and transportation costs (the costs to move commodities from producers to purchasers) are unchanged.

The total value-added for the total economy remains unchanged; the value-added estimate for transportation industries is increased by the amount of value-added by the self-transportation that is subtracted from other industries' value-added. In addition, although the output for each industry remains unchanged, the total gross output for all industries is increased by the amount of output identified for the self-transportation industry; this is because the total of all purchases of intermediate inputs - including self-transportation services - by industries is increased by the same amount as the sum of the self-transportation industry output

The TSAs differ from the IO accounts only because of the specific need to separately measure self-transportation. In the TSAs, self-transportation is treated as a separate industry where the only output is self-transportation service. The use of self-transportation by an industry includes the costs of operating an industry's own trucks and buses, whether or not those vehicles are used to move an industry's intermediate inputs or its output. In the IO accounts the use of commercial-transportation by an industry includes only those transportation expenses associated with moving intermediate inputs to the industry, plus the expenses for certain direct transportation services. For example, if commercial-transportation carries wheat from a farm to a mill, the IO use table credits this activity to the mill, even though the farm may have purchased the transportation service. However, if a self-transportation of the mill transports the wheat from the farm, the TSAs use table shows the mill as providing the services, and if a self-transportation of the farm transports the wheat to the mill, the TSAs use table credits this activity to the farm [15].

4.5.4.3 Component of the TSA

According to TSA [15], the TSA data are presented in four tables: Make (production) table, Use (consumption) table, Direct Requirements table, and Industry-by-Commodity Total Requirements table. In which the first two tables, respectively, present commercial-transportation and self-transportation data in an IO framework. The third one presents data on industry use of intermediate and value-added inputs as a percentage of the industry output. The last table shows industry-by-commodity multipliers. The following paragraphs explain those tables in detail.

1. **TSA Make Table.** The IO make table with an additional column for self-transportation as a commodity and an additional row for an aggregation of all redefined self-transportation activities as a new industry. The IO make table shows the value in producers' prices of each commodity produced by each industry. In each row, the cell on the main diagonal shows the value of the production of the commodity for which the industry has been designated the primary producer. The other cells in the row show the value of the production of commodities for which the industry is a secondary producer. The sum of all the entries in a row is the total output of that industry.

In the TSAs make table, the cell value at the intersection of the in-house transportation column and row equals the total output of self-transportation; all other cell entries in the self-transportation column and row are zero.

2. **TSA Use Table.** This table is an IO use table with an additional row for self-transportation services and an additional column for an aggregation of all redefined self-transportation activities as a new industry. An IO use table shows the values, in producers' prices, of self-transportation and all other intermediate and value-added inputs consumed by industries or final users. The cell in each row of a given column shows the commodity that is used by the industry or final user in that column. The sum of all the entries in a row is the total output of the commodity in that row, and the sum of all the entries in a column is the total output of the industry in that column.

In the TSAs use table the use of the self-transportation services commodity is shown in the self-transportation row. Because self-transportation services are provided by non transportation industries for their own-use, the following cell values are equal to zero: the cell value at the intersection of the self-transportation row and column (the use of self-transportation services to support self-transportation activities), and the cell values at the intersections between the self-transportation

row and the commercial-transportation columns (the use of self-transportation services to support commercial-transportation activities).

3. **TSA Direct Requirements Table.** In this table, each cell shows the direct requirement per dollar output of the industry (on the column) for the commodity (on the row), which is also referred to as the "direct requirement coefficient." The sum of an industry's direct requirement coefficients for intermediate inputs and value-added categories is equal to one. The TSAs direct requirements table is derived from the TSAs use table by dividing each industry's commodity and value-added inputs by that industry's total output. Unlike the TSAs use table, however, this table does not include the components of final use or GDP. In table 4, each column shows, for the industry named at the head of the column, the input coefficients for the commodities and for the value-added components that an industry directly requires to produce a dollar's worth of output.
4. **TSA Industry-by-Commodity Total Requirements Table.** This table shows the total requirements coefficients for each industry's output that is directly and indirectly required to deliver a dollar's worth of goods and services to consumers and other final users. Each column shows the commodity delivered to final users, and each row shows the demand for an industry's output in response to a dollar increase in the final demand for a commodity. The coefficients in the table are referred to as industry-by-commodity total requirement coefficients. The table is derived from both the TSAs make and the TSAs use tables.

The last row of the table shows the sum of all the changes in industry outputs that are required to deliver a dollar's worth of goods and services to final users. Because each of these sums is a dollar multiple of the initial dollar spent for an industry group's output, the sum is often referred to as an "output multiplier." These multipliers can be used to estimate the impact of changes in the final demands of commodities on total industry output. Hence, this table shows the interdependencies among the producers and consumers in the economy and can be used to derive estimates of the direct and indirect effects of changes in final demands on commercial and self-transportation industries and commodities. For example, this table can be used to analyze the relative effects on transportation and non-transportation industries of an increase in personal consumption expenditures or of a change in the composition of fixed investment that results from a change in business activity

4.5.5 TSA for Vietnam and IRIO

The current IRIO table 2005 for Vietnam is used as one of the input data for simulation of the multi-regional CGE model. In the IRIO table, the country is divided into 8 regions and comprises 28 sectors. The framework of Vietnam IRIO table has shown in the Fig. 4.1.

In the current Input-output table as well as IRIO table of Vietnam, there have no transportation services data of both the value of commercial- transportation and self-transportation services. In which commercial-transportation services are provided by transportation firms to industries. The sizable contribution of self-transportation that take place within non-transportation sectors, was not explicitly identified. Hence, in order to create the transport satellite accounts (TSA) for Vietnam as a relatively new tool to measure and analyse the transport sector as a whole, self-transportation and commercial-transportation should be introduced in the IRIO table.

From existing IRIO table, the transport sector is replaced by commercial-transportation. In addition, another sector, self-transportation is introduced. The both commercial-transportation and self-transportation are derived from the transport sector in the original IRIO table. We assume the ratio between the two is fixed at 9:1. The framework of new IRIO which is included commercial-transportation and self-transportation as shown in the Fig. 4.3.

Notation of the new IRIO framework

- X_{ict}^{rs} commercial-transportation used to transport goods i from region r to region s
- X_{ist}^{rs} self-transportation service used by firms i
- T_{ct}^s total commercial-transportation service used by firms in region s
- T_{st}^s total self-transportation service used by firms in region s
- X_{ist}^{rs} self-transportation service used by firms i

Calculation of the new IRIO table with two additional sectors which are commercial-transportation and self-transportation conducts in the Appendix A ?? of this thesis.

4.6 Summary and Recommendations

This chapter describes about data base preparation for the research. The characteristics and development of Vietnamese economic data are mentioned. The chapter mainly focuses on input-output table data of Vietnam after overview input-output systems in

from	to	Intermediate demand						Final demand			Output
		Region 1			Region s			Region s	ROW		
		1..j..n	CTR	STR	1..j..n	CTR	STR	1..k	E	M	
Region 1	1	X_{1j}^{11}	X_{1ct}^{11}	X_{1st}^{11}	X_{1j}^{1s}	X_{1ct}^{1s}	X_{1st}^{1s}	DY_{1k}^{1s}	E_1^{1w}		X_i^1
	.										
	i	X_{ij}^{11}	X_{ict}^{11}	X_{ist}^{11}	X_{ij}^{1s}	X_{ict}^{1s}	X_{ist}^{1s}	DY_{ik}^{1s}	E_i^{1w}	0	
	.										
	n	X_{nj}^{11}	X_{nct}^{11}	X_{nst}^{11}	X_{nj}^{1s}	X_{nct}^{1s}	X_{nst}^{1s}	DY_{nk}^{1s}	E_n^{1w}		
	CTR	X_{ctj}^{11}	X_{ctct}^{11}	X_{ctst}^{11}	X_{ctj}^{1s}	X_{ctct}^{1s}	X_{ctst}^{1s}	DY_{ctk}^{1s}	E_{ct}^{1w}		
	STR	X_{stj}^{11}	X_{stct}^{11}	X_{stst}^{11}	X_{stj}^{1s}	X_{stct}^{1s}	X_{stst}^{1s}	DY_{stk}^{1s}	E_{st}^{1w}		
Region r	1	X_{1j}^{r1}	X_{1ct}^{r1}	X_{1st}^{r1}	X_{1j}^{rs}	X_{1ct}^{rs}	X_{1st}^{rs}	DY_{1k}^{rs}	E_1^{rw}		X_i^r
	.										
	i	X_{ij}^{r1}	X_{ict}^{r1}	X_{ist}^{r1}	X_{ij}^{rs}	X_{ict}^{rs}	X_{ist}^{rs}	DY_{ik}^{rs}	E_i^{rw}	0	
	.										
	n	X_{nj}^{r1}	X_{nct}^{r1}	X_{nst}^{r1}	X_{nj}^{rs}	X_{nct}^{rs}	X_{nst}^{rs}	DY_{nk}^{rs}	E_n^{rw}		
	CTR	X_{ctj}^{r1}	X_{ctct}^{r1}	X_{ctst}^{r1}	X_{ctj}^{rs}	X_{ctct}^{rs}	X_{ctst}^{rs}	DY_{ctk}^{rs}	E_{ct}^{rw}		
	STR	X_{stj}^{r1}	X_{stct}^{r1}	X_{stst}^{r1}	X_{stj}^{rs}	X_{stct}^{rs}	X_{stst}^{rs}	DY_{stk}^{rs}	E_{st}^{rw}		
GVA	1	V_{1j}^{v1}	X_{1ct}^{v1}	X_{1st}^{v1}	V_{1j}^{vs}	X_{1ct}^{vs}	X_{1st}^{vs}				GDP
	.										
	i	V_{ij}^{v1}	X_{ict}^{v1}	X_{ist}^{v1}	V_{ij}^{vs}	X_{ict}^{vs}	X_{ist}^{vs}	0	0	CDT	
	.										
	n	V_{nj}^{v1}	X_{nct}^{v1}	X_{nst}^{v1}	V_{nj}^{vs}	X_{nct}^{vs}	X_{nst}^{vs}				
Total gross input		X_j^1	T_{ct}^1	T_{st}^1	X_j^s	T_{ct}^s	T_{st}^s	$\sum DY$	$\sum E$	$\sum M$	

FIGURE 4.3: New IRIO table for Vietnam with commercial-transportation and self-transportation sectors

general. To produce output, sectors require each other's inputs. The economy is classified by sectors, the sectors may have a variety of commodities as inputs and their outputs are not mixed. Each sector is identified with the commodity that it produces. Chapter 4 also provides the development of Input-Output analysis for Vietnamese economy. One of the novelties in this thesis which is the establishment of transportation data for Vietnam also provided in this chapter.

An adaption of transportation satellite accounts of Bureau of Transportation Statistics, US Department of Transportation [15] for estimating the size and role of transportation in the economy of Vietnam. This new accounting tool provides a way to measure both self-transportation and commercial-transportation services. The TSA reveal several

important features concerning the relationship between transportation and the economy. A key concern addressed by the TSA is credibility of transport estimates.

Since both self-transportation and commercial-transportation services are not identified as a separate activity in any current IO table and IRIO table of Vietnam. By creating new IRIO table in which TSA is derived from the existing IRIO, it provides details estimation of intermediate inputs purchases by firms including commercial-transportation service sectors. New IRIO table brings together the information by essentially reorganizing the national accounts and supplementing them with additional concepts and data, and thus develop relatively credible quantification of different aspects of transportation. The data has been made is use for simulation of the Multi-Regional CGE model which structurally presents in chapter 5 and a simulation results and discussion are shown in the chapter 6.

Chapter 5

CGE Modeling with Freight Transport and Passenger Flows

5.1 General Introduction

Recently computable general equilibrium (CGE) methods are become more and more popular for estimating the welfare effects of infrastructure investment. Most of CGE applications, however, so far have only taken the impacts of commodity transport cost into consideration. Welfare effects are due to time and cost savings in passenger transport should be considered. This paper introduces a multi-regional CGE model for single country's economy which is used to study the regional economic effects of transportation infrastructure investment. We consider a country's economy with number of sectors and one explicit sector as transportation. The country divided into regions. Transportation infrastructure investment makes changes to productivity of the commodity and trade margin. Applying the CGE model, we explore the impacts of reducing transport costs from transportation infrastructure investment among regions, estimating the effects on the change of commodity flow volume and welfare effect. The data bases for empirical study of the model are aggregated from interregional Input-Output table 2007 for Vietnam and derived data from GTAP data base version 7.

5.2 CGE Modeling analysis and transport

The globalization and internationalization of production and trade are inevitably leading to a growth in the demand for international transportation in all over the world. The result is increased amounts of international traffic and more international personal

mobility. The forecasts are that the trend is far from being transient but that longer-term growth in international trade and in international travel will continue into the foreseeable future.

The interface between infrastructure transportation investment and economic development has broad ramifications that go beyond transportation's basis purpose of moving goods and people from one place to another. Whereas there is no doubt that transportation is essential in the operation of a market economy, much still needs to be understood about ways in which an efficient transportation system can improve the productivity of the economy.

Recently CGE model analyses are becoming more essential tool and more popular for estimating the effect of transportation infrastructure investments on the economy, to fill up the requirement of the differentiation among regions. Almost CGE applications up to now only taken the impacts of goods transport costs into consideration. Few studies extended and paid attention on welfare effects that are due to the time and costs savings in passenger transport. So far many researches are already made for assessing the important of infrastructure investments as well as costs and benefits of individual projects, however, not many study is about the spatial distribution of the benefits. There are numerous methods using for this purpose.

Aschauer [1] and Pfahler [2] measured benefits by estimating rates of return on infrastructure investment in a production function approach, using cross section, time series, in which the regional distribution of effects is concerned. When accessibility changes it may raise regional affects in different way, depending on the pattern of interregional flows. Spiekermann [3] approaching method is to measure the impact of transport cost reductions by accessibility indicator showing how a region's generalized cost of reaching its markets and of traveling to a hypothetical set of destinations is affected by the costs reductions. Next, accessibility changes are then related to regional economic indicators like GDP per capita or real growth of GDP. Passenger transport systems are the foundation of economy so that households and private firms can utilize them in consumption and production activities.

5.3 A Multi-regional CGE Model

5.3.1 Introduction

The multiregional CGE models have been paid attention in order to assess the regional policies changes include infrastructure transportation investments. The pioneering studies by Dixon [129] developed a top-down model that decomposes national variables into regional. Liew *et al.*, [4], developed static Multiregional Variable Input-Output (MRVIO) model considers price differentials due to transportation within a multiregional I-O model. Recent years, a multiregional CGE has been raised in which transport costs explicitly appear as firm's expenditures for transport and other kinds of business travel and as households' costs of private passenger travel.

CGE models with a spatial dimension have been applied to transportation infrastructure investments by several authors Brocker 2001 [5], Ueda *et al.*, 1999, and Venable 1998). However, there have limitations in these models, for instant, they considered to trade costs and regardless the costs of passenger travel or inverse, they consider costs of business trip but disregard transportation cost for commodities.

During 2000s, Horridge *et al.*, [8] developed a bottom-up model named TERM (The Enormous Regional Model) which used to assess the regional impacts of an economic event in a country, and the database from non-survey regional I-O tables and an inter-regional trade matrix. The original version of TERM is a comparative static model. It shows, for a single year, the differences produced in the regional economies by changes in taxes, technology, tariffs and other exogenous variables. Various versions of TERM have been prepared for several countries including Brazil, Finland, China, Indonesia, South Africa, Poland, and Japan.

More recently, Sharina *et al.* [9] have discussed the current issue in globalization and optimum production allocation of heterogeneous firms. They proposed a two countries general equilibrium model that integrates the comparative advantages theory and new economic geography theory. The model mainly applied in heterogeneous firms that consider the costs associated with the different production technologies between firms and transportation cost between two countries.

This chapter introduces a multiregional CGE model for Vietnam. It deals with the effects of infrastructure transportation investment in commodities transportation cost of interregional trade and households' welfare effects due to the time and cost saving in passenger transport. The passenger transport includes business trips and individual

resident travel. In the economy, the country divided into three regions, there are four sectors and one of them is transport which linked the regions.

The model includes the following purposes: (i) to develop a multi-regional CGE model that explicitly considers the transportation sector, (ii) explore the impacts of reducing transport costs from transportation infrastructure investment among Vietnamese regions, and (iii) estimating the effects on the change of commodity flow volume and passenger travel cost. The data bases of the model are aggregated from interregional I-O table 2005 for Vietnam and the I-O table which derived from GTAP data base version 7.

5.3.2 Structure of the Model

5.3.2.1 Overview

In each region has a population of households owning a bundle of production factors include labor and capital which used by regional firms for producing commodities. Beside, the inputs of the firms include transportation costs of commodities which are freight transport.

The model focuses on three following roles of freight transport: 1) firm provides commodities by inputting labor, capital and intermediate inputs; 2) household consumes commodities which are produced within region or from other regions; 3) the model includes the freight transport demand as a part, in which the total demand is to be endogenous so that we can explicitly deal with the induces demand of freight transport and the induced final demand for commodities at the destination. The intermediate inputs of the firms come from other firms in the region and itself. The outputs are sold out of the regions and within the own region.

Commodities transferred from the origin to the destination required transportation cost of commodities. The cost amount of freight transport per unit of trade commodities is a function of the state of transportation infrastructure, and the extra cost is added for interregional flows. Passenger transport systems is neglected in this paper, however, it will be introduced in the straightforward stage which extended from this study.

Regional final demand, including investment and public sector demand, is modeled as expenditure of utility maximizing regional households, who spend their total disposal income in the respective period.

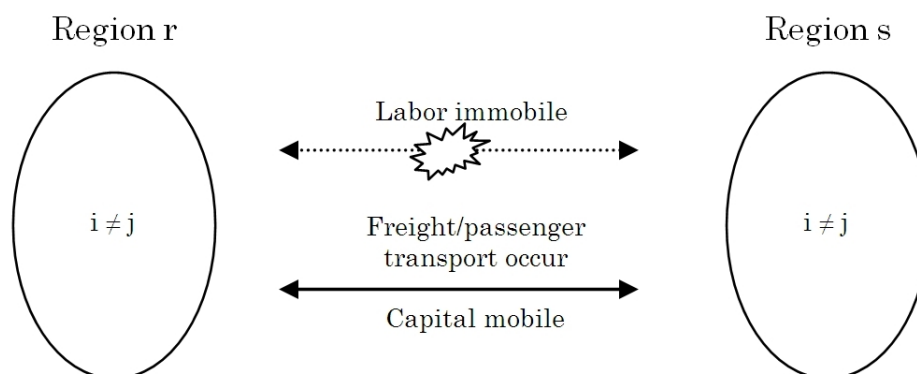

FIGURE 5.1: The assumptions of the model

The behavior of economic agents within and between each region is explicitly considered. Each firm in the model operating within each of the regions is assumed to minimize costs subject to constant returns to scale production technologies. A representative utility-maximizing household resides in each of the models' regions. Imperfect substitutability between the imported and the domestic sources of supply for each commodity are modeled using the CES assumption of Armington.

This chapter aims to analyze the economic effects by transportation infrastructure improvement and utilize similar concept to Koike *et al.*, [130]. However, the differences between the two are: Koike regarded transport input as a component of value added, this paper regards transport cost is the changes in prices of commodities.

5.3.2.2 Main Assumptions

The model in this paper has the following assumptions. The country consists of regions labeled by $(r, s = 1, \dots, S | r \neq s)$; each region consists of representative household, sectors labeled $(i, j = 1, \dots, I | i \neq j)$, and a transportation sector ($i = T$); each firm provides commodities by using factors labeled by $(k = 1, \dots, K | K = 2)$, namely $k = 1$ is labor input, $k = 2$ is capital input are supplied by household and intermediate goods. The households earn income by supplying factors and consume commodities provided by firms. The transportation sector provides freight transport for the firms. Markets are assumed to be perfect competition.

The model obtains the equilibrium when all the goods markets including transportation services are cleared, the labor market and capital market are cleared. The transportation infrastructure links the regions and used for interregional trade of goods. The locations of the regions are exogenously fixed. The population of each region is also exogenously fixed and immobile. The structure of the model as shown in the Fig.5.1

The model, regional demands and supplies of commodities are determined through optimizing behavior of agents in competitive markets. Optimizing behavior also determines demands for labor, capital and intermediate goods. The mobility of production factors is a critical feature of every general equilibrium model. Capital can cross regional borders in response to capital- market conditions and the total capital stock of the economy is fixed. The capital is equally owned by households and each of them can receive an equal share in capital rent as a part of their income. Labor is assumed regionally immobile means the population of each region is exogenously fixed. The transportation system is used for inter-regional trade of commodities.

5.3.2.3 Firms' behaviour

Each firm is assumed to maximize profits, defines as the difference between revenue earned and the cost of factors and intermediate inputs. As stated above assuming that all markets are perfectly competitive and technologies have constant returns to scale. Production technology is represented in Fig.5.2. At the first stage, the output level of commodity in each region is decided upon by combining inputs of primary factors which is made up by labor and capital. The first level is characterized by fix proportions of various inputs which mean assuming that input coefficients of intermediate goods are fixed. Hence, the production function is in Leontief type technology.

At the second level the firm is discrete and represented to amount of capital and labor which are combined to produce value-added and sourcing of the intermediate inputs from the other firms. In the third level, it is characterized by fixed proportions of either transportation service or the quantity of intermediate input from any of r regions. Thus the third level production decision is specified as of the Leontief type.

According to the structure in Fig.5.2, the maximization profit of the firms is equivalent as follows.

Stage (i) is the optimization problem respect to the composite intermediate input goods x_{ij}^s and value-added VA_j^s .

$$\pi_j^s = \max p_j^s Q_j^s - \left\{ \sum_{i \in I} p_{ij}^s x_{ij}^s + uc_{V_j}^s (r, w^s, z_j^s) VA_j^s \right\}, \quad (5.1)$$

$$\text{subjected to } Q_j^s = f_j^s (x_j^s, VA_j^s), \quad (5.2)$$

Stage (ii) is the optimization problem respect to factor input labor and capital f_{kj}^s .

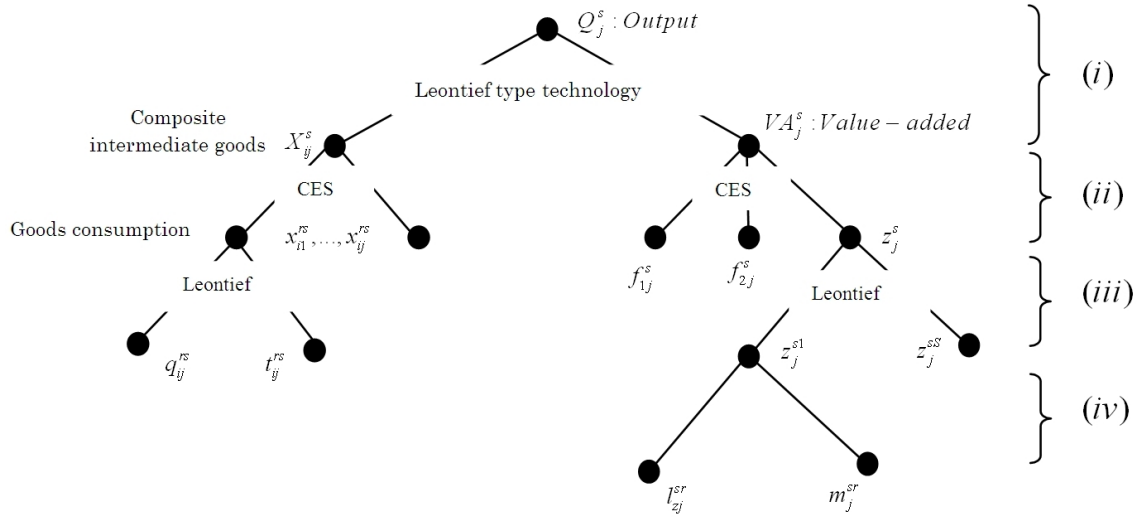

FIGURE 5.2: Production technology.

$$uc_{V_j}^s(r, w^s, z_j^s) VA_j^s = \min [r f_{1j}^s + w^s f_{2j}^s + p_{zj}^s z_j^s] , \tag{5.3}$$

$$\text{subjected to } VA_j^s = f_j^{2s}(f_{1j}^s, f_{2j}^s, z_j^s) , \tag{5.4}$$

Stage (iii) is the optimization problem respect to business trip input z_j^{rs} .

$$z_j^s(l_{zj}^{sr}, m_j^{sr}) = \min \left(\sum_r p_{zj}^{sr} z_j^{sr} \right) , \tag{5.5}$$

$$\text{subjected to } z_j^s = f_j^{3s}(z_j^{sr}, l_{zj}^{sr}, m_j^{sr}) , \tag{5.6}$$

where

p_j^s is the producer's price of goods j in region s

Q_j^s is total output of firms j in region s

p_{ij}^s is the consumer's price of goods produced by firms i in region r imported for firms j in region s

$uc_{V_j}^s$ is the unit cost function for VA_j^s

VA_j^s is compound goods of input factors (labor, capital and business trip) formed to value added of firms j in region s

x_{ij}^s is the intermediate input of firms i to the firms j in region s

r, w^s is the capital rent and wage rate of the firms j in region s

f_{1j}^s, f_{2j}^s are the function of input factors

l_{zj}^{sr} is the travel time per unit of business trip z_j^{sr}

z_j^{sr} is the business trip of labor of firm j in regions s from region r

p_{zj}^s is the price of business trip of labor of firm j in regions s from region r

m_j^{sr} is the transportation cost for business trip from regions r to region s

where $l_{zj}^{sr} = \frac{L_{ij}^{sr}}{T^{sr}}$, L_{ij}^{sr}, T^{sr} are the transport service and total working hour, respectively.

Next, we specify the production functions as follows.

Stage(i), the optimization problem follows Leontief type technology function.

Production sectors other than transport sector applying cost minimization, we assume that an industry behaves so as to minimize production cost as formulated:

$$p_j^s Q_j^s = \min \left(\sum_{i \in I} p_{ij}^s x_{ij}^s + \sum_{k \in K} \omega_{kj}^s V A_j^s \right), \quad (5.7)$$

$$\text{subjected to } Q_j^s = \min \left[\frac{V A_j^s}{a_{vj}^s}, \frac{x_{ij}^s}{a_{ij}^s} \right], \quad (5.8)$$

in which ω_{kj}^s is the corresponding factor price

a_{vj}^s is value added rate of firms j in region s

a_{ij}^s is the input coefficient for intermediate input

Stage (ii), the optimization problem follows CES type technology function.

The firm j in region s produce output Q_j^s with the intermediate inputs imported from other regions and/or region s itself and with the primary inputs follow CES production function below.

$$x_{ij}^s = \left[\sum_{r \in S} \alpha_{ij}^s x_{ij}^{rs} \frac{\sigma_1 - 1}{\sigma_1} \right]^{\frac{\sigma_1}{\sigma_1 - 1}}, \quad (5.9)$$

Parameter α_{ij}^s are the fixed intermediate goods requirements in region s per unit production of good j and VA_j^s represents the composite primary factor or the value added in producing good j in region s being presented in the CES function.

$$VA_j^s = \left[\sum_{k \in K} \delta_{kj}^s f_{kj}^s \frac{\sigma_2 - 1}{\sigma_2} \right]^{\frac{\sigma_2}{\sigma_2 - 1}}, \quad (5.10)$$

According to Shepard's lemma, cost minimization behavior yields the technology coefficient in term of intermediate input goods and value-added coefficients derivatives of nest CES unit cost function $uc_{V_j}^s$ with respect to individual prices.

$$\alpha_{ij}^s = \frac{\partial uc_{V_j}^s(p^s, \omega^s, \alpha_j^s, \delta_j^s)}{\partial p_{ij}^s}, \quad (5.11)$$

$$\delta_{kj}^s = \frac{\partial uc_{V_j}^s(p^s, \omega^s, \alpha_j^s, \delta_j^s)}{\partial \omega_{kj}^s}, \quad (5.12)$$

The price relation equations between $p_i^s, p_{ji}^s, \omega_{kj}^s$ represents as follow,

$$p_i^s = \sum_i \alpha_{ij}^s p_{ij}^s + \sum_k \delta_{kj}^s \omega_{kj}^s, \quad (5.13)$$

In term of the composite intermediate inputs x_{ij}^s in producing goods j in region s being represented by CES function,

$$p_{ij}^s x_{ij}^s = \min \sum_{i \in I} p_{ij}^{rs} x_{ij}^{rs}, \quad (5.14)$$

subjected to recall Eq.5.9.

The price relation equations between p_{ij}^s, p_{ji}^{rs} represents as follow,

$$p_{ij}^s = \left[\sum_i (p_{ij}^{rs})^{1-\sigma_1} \right]^{\frac{1}{1-\sigma_1}}, \quad (5.15)$$

The composite primary input VA_j^s in producing goods j in region s being represented by CES function,

$$\omega_{kj}^s VA_j^s = \min (r f_{1j}^s + w^s f_{1j}^s + p_{zj}^s z_j^s), \quad (5.16)$$

$$\text{subjected to } QVA_j^s = \left(f_{1j}^s \frac{\sigma_2-1}{\sigma_2} + f_{1j}^s \frac{\sigma_2-1}{\sigma_2} + z_j^s \frac{\sigma_2-1}{\sigma_2} \right)^{\frac{\sigma_2}{\sigma_2-1}}, \quad (5.17)$$

The price relation equations between r , w^s , $p_{z_j}^s$ represents as follow,

$$\omega_{kj}^s = \left(r^{1-\sigma_2} + w^{s1-\sigma_2} + p_{z_j}^s \right)^{\frac{1}{1-\sigma_2}}, \quad (5.18)$$

Stage(iii), the optimization problem follows Leontief type technology function.

The business trip z_j^s represents as follow

$$p_{z_j}^s z_j^s = \min \sum_r p_{z_j}^{sr} z_j^{sr}, \quad (5.19)$$

$$\text{subjected to } z_j^s = \left(\sum_r z_j^{sr} \frac{\sigma_3-1}{\sigma_3} \right)^{\frac{\sigma_3}{\sigma_3-1}}, \quad (5.20)$$

in which $p_{z_j}^s$ is the price of composite z_j^s

$p_{z_j}^{sr}$ is price of transport service of z_j^s from region r to firms j in region s

σ_2, σ_3 are the parameters

Stage (iv), the optimization problem follows Leontief type technology function.

$$p_{z_j}^s z_j^s = \min \sum_r p_{z_j}^{sr} z_j^{sr}, \quad (5.21)$$

$$\text{subjected to } \min \left(\frac{l_{z_j}^{sr}}{\gamma_1}, \frac{m_j^{sr}}{\gamma_2} \right), \quad (5.22)$$

where $l_{z_j}^{sr} = \frac{L_{z_j}^{sr}}{T^{sr}}$, $L_{z_j}^{sr}, T^{sr}$ are the transport service and total working hour, respectively.

$$p_{z_j}^{sr} = \frac{\gamma_1 w^s}{T^{sr}} + \gamma_2 p_m^{sr}, \quad (5.23)$$

5.3.2.4 Households' behaviour

The representative household in the model maximize their utility by consuming commodity and/or services produced in the same region. The structure of household's

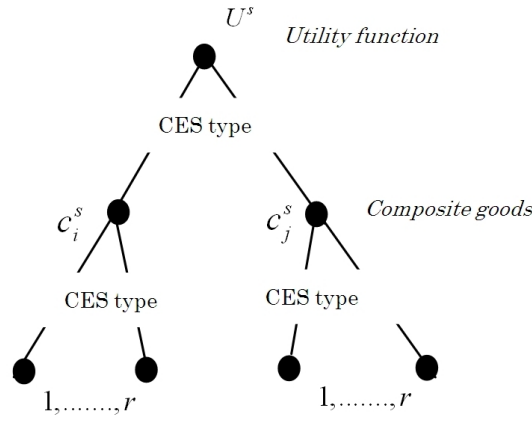

FIGURE 5.3: The structure of household's utility function.

utility function as shows in the Fig.5.3 Utility function U^s is specified as CES type and the aggregate utility of households in region s is considered depend on the amount of composite commodity produced in regions r consumed in regions s . At the second level, the composite goods come from different regions. The household behavior is formulated follows the utility maximizing problem subject to the budget.

$$U^s = \max \left[\sum_{i \in I} \gamma_j^s \frac{1}{\sigma_4} (c_j^s)^{\frac{\sigma_4-1}{\sigma_4}} \right]^{\frac{\sigma_4}{\sigma_4-1}}, \quad (5.24)$$

$$\text{subjected to } \sum_{j \in I} p_j^s c_j^s = Y^s, \quad (5.25)$$

in which

U^s is the utility function

c_j^s is the consumption level of commodity j in region s

p_j^s is the consumption price of commodity j of region s

Y^s is the total household's income where γ_j^s, σ_4 are parameters. Total income of household is calculated as follows:

$$Y^s = \sum_j r f_{1j}^s + \sum_j w^s f_{2j}^s, \quad (5.26)$$

Solving the equations above, we obtaine the following demand function.

$$c_j^s(p) = \frac{\gamma_j^s (p_j^s)^{1-\sigma_4} Y^s}{\sum_j \gamma_j^s (p_j^s)^{1-\sigma_4} p_j^s}, \quad (5.27)$$

Substitution Eq.5.27 to the Eq.5.24 we obtain

$$U^s(p, Y) = \left[\sum_j \gamma_j^s (p_j^s)^{1-\sigma_4} \right]^{\frac{1}{\sigma_4}} Y^s, \quad (5.28)$$

The price relation equation of p_j^s represents as follow,

$$p_j^s = \left[\sum_i (p_{zj}^{sr})^{1-\sigma_4} \right]^{\frac{1}{1-\sigma_4}}, \quad (5.29)$$

At the second level, the composite goods come from different regions. The household behavior is formulated follows the utility maximizing problem subject to the budget.

$$p_{hj}^s c_j^s = \min \sum_r p_{hj}^{rs} c_j^{rs}, \quad (5.30)$$

$$\text{subjected to } c_j^s = \sum_{r \in S} \left(c_j^{rs} \frac{\sigma_5 - 1}{\sigma_5} \right)^{\frac{\sigma_5}{\sigma_5 - 1}}, \quad (5.31)$$

in which

p_{hj}^s is the household's price of commodity j in region s

c_j^{rs} is the commodity j produced in region r consumed in region s

where σ_5 are parameters

The price relation equation of p_{hj}^s represents as follow

$$p_{hj}^s = \left[\sum_i (p_{hj}^{rs})^{1-\sigma_5} \right]^{\frac{1}{1-\sigma_5}}, \quad (5.32)$$

where p_{hj}^{rs} is the household's price of commodity j in region s

5.3.2.5 International Trade model

In term of import

Commodity trade between regions including different regions and rest of the world generates the demand for transport services. The transportation cost and the pattern of trade flows are reflected through the price gaps between the regions.

The standard small-country economy assumption in simple commodity trade models is that the world price is fixed which is the country modeled is a price-taker and the domestic good is a perfect substitute for the foreign traded commodity, so that the law of one price holds. However, in this model because of given the high level of aggregation in the economy, for importable, the Armington assumption is assumed.

Trade economists have modeled imperfect substitution between home and foreign goods in consumption with a little analysis of what explains the wide variation in this substitution elasticity across sectors. Mean that the domestic's firms use unit of common composite goods from other geographic origins The domestic demand for composite commodity is defined as CES function of imported goods and domestically produced commodities. This formulated as minimization problem. The first order of the cost minimization problem expresses the ratio of imported goods to domestically produced goods. The minimizations problem formulated as follows

$$\min p_j^s Q_{jD}^s = p_j^{Ms} x_{jM}^s + p_j^{Ds} x_{jD}^s, \quad (5.33)$$

$$\text{subjected to } Q_{jD}^s = \theta_{jM}^s [\delta_{jM}^s (x_{jM}^s)^{-\rho_j^M} + (1 - \delta_{jM}^s) (x_{jD}^s)^{-\rho_j^M}]^{-1/\rho_j^M}, \quad (5.34)$$

in which

p_j^s is the price of composite goods in region s

Q_{jD}^s is the domestic demand of composite goods in region s

p_j^{Ms}, p_j^{Ds} are the price of imported and domestic goods, respectively

x_{jM}^s, x_{jD}^s are the imported and domestically produced goods, respectively

Solve the equations above in order to minimize the cost of obtaining a unit of Q_{jD}^s , the optimal mix between imports and domestically produced is defined in equation below.

$$\frac{x_{jM}^s}{x_{jD}^s} = \left(\frac{\delta_{jM}^s p_j^{Ds}}{1 - \delta_{jM}^s p_j^{Ms}} \right)^{1/(1 + \rho_j^M)}, \quad (5.35)$$

where $\sigma_j^M = 1/(1 + \rho_j^M)$ is the trade substitution elasticity, the larger the value for σ_j^M the greater the sensitivity of the share of imports in total supply to price changes.

In term of exports At the next stage, production output Q_i^s is allocated between exports E_i^s and domestic sales Q_{Di}^s on the assumption that supplier maximize sales for given aggregate output level, subject to imperfect transformability between exports and

domestic sales. The domestic price at p_i^{Dr} is regarded as the common price excluding transport cost for domestic sales to the market in all regions. The optimal problem formulated as follows:

$$\max p_j^s Q_j^s = p_j^{Dr} C_{Dj}^s + p_j^E E_j^s, \quad (5.36)$$

$$\text{subjected to} \quad Q_j^s = \theta_{jE}^s [\delta_{jE}^s (C_{Dj}^s)^{-\rho_j^E} + (1 - \delta_{jE}^s) (E_j^s)^{-\rho_j^E}]^{-1/\rho_j^E}, \quad (5.37)$$

in which

C_{Dj}^s is the domestic sales of goods j in region s

E_j^s is the export volume of goods j in region s

p_j^{Dr}, p_j^E are the domestic and export price of goods j

The optimal mix between exports and domestic sales is defined as follow equation below. The firm maximizes profit by setting the marginal rate of transformation equal to the relation price ratio, supply optimal levels of output to each market.

$$\frac{E_j^s}{C_{Dj}^s} = \left(\frac{\kappa p_j^E}{p_j^{Ds}} \frac{\delta_{jE}^s}{1 - \delta_{jE}^s} \right)^{1/(1 + \rho_j^E)}, \quad (5.38)$$

$$\frac{x_{jM}^{rs}}{x_{jD}} = \left(\frac{\delta_{jM}^s}{1 - \delta_{jM}^s} \frac{p_j^{Ds}}{p_j^{Ms}} \right)^{1/(1 + \rho_j^M)}, \quad (5.39)$$

where $\sigma_j^E = 1/1 + \rho_j^E$ is the trade substitution elasticity, the larger the value for σ_j^E the greater the sensitivity of the share of exports in total supply to price changes.

5.3.2.6 Equilibrium Conditions

In the model, the firms' production function technology has the property of constant return to scale because of CES type technology. Each firm produces maximizing to meet consumers demand. The supply-demand balance for firm's product always holds for each one. The equilibrium conditions in the market for goods market, transport services market and factor markets are followed:

Commodity market, for each region s :

$$Q_j^s = \sum_{r \in S} \sum_{i \in I} x_{ij}^{rs} + \sum_r c_j^{rs} + E_j^s - x_{jM}^s, \quad (5.40)$$

Labor market, for each region s :

$$f^s = \sum_{j \in I} f_{1j}^s + \sum_{j \in I} \sum_{r \in S} L_{zj}^{sr} + \sum_r (L_{mj}^{sr} + L_{tzj}^{sr}) + L_{mj}^s, \quad (5.41)$$

The capital market:

$$f_2 = \sum_{j \in I} \sum_{s \in I} f_{2i}^s + \sum_s f_{2m}^s + \sum_s k_j T^{rs}, \quad (5.42)$$

in which

$Q_i^s Q_i^s$ is total output of all firms in region s

$c_i^s c_i^s$ is total consumption level of all commodity in region s

$c_i^{rs} c_i^{rs}$ is total consumption level of commodity s produced in region r transported to region s

f_1^s, f_2^s is total labor and capital factors supply to the all firms excluding transport sector in region s , respectively.

5.3.3 Economic Effect Analysis

Households Welfare The economic effect of the infrastructure transport investment in this study is defined by the concept of Equivalent Variation. That is the equivalent income increases and the change in money that would lift the household up the new indifferent curve at the existing prices. Equivalent Variation measures the scale of welfare change obtained through transport infrastructure investment that would the households on a higher utility level at previous prices. The profits of the firms in the equilibrium condition are all zero including transport sector and the welfare gains go to the household. The value of the equivalent variation is given in terms of the expenditure function as follows:

$$EV^s = e(P^s, U_{(n)}^s) - e(P^s, U_{(o)}^s) = \frac{U_{(n)}^s - U_{(o)}^s}{U_{(o)}^s} C_h^o, \quad (5.43)$$

in which

$EV^s EV^s$ is equivalent variation of a price change on households

$U_{(o)}^s U_{(o)}^s$ is utility level of households before infrastructure transport upgrading

$U_{(n)}^s U_{(n)}^s$ is utility level of households after infrastructure transport upgrading

5.4 Discussion and Conclusion

In this chapter, we developed a multi-regional, multi-sector CGE model that concentrates in particular on case of Vietnam. The model descriptions particular emphasis on the theoretical structure and the equations linkages used in the CGE framework. The multi-regional CGE model for single country's economy developed which is used to study the regional economic effects of transportation infrastructure investment. We consider a country's economy with number of sectors, the country divided into various regions. Transportation infrastructure investment makes changes to productivity of the firm's commodity.

Applying the CGE model, we explore the impacts of reducing transport costs from transportation infrastructure investment among regions, estimating the effects on the change of commodity flow volume and welfare effect due to both commodity freight transport and passenger flows. The important novelty in the model is the incorporate time resources of human business trip and commodity transport into the production function. The data bases for empirical study of the model are aggregated from interregional Input-Output table 2005, Input-Output Table 2005 for Vietnam and derived data from GTAP data base version 7 which is made in previous chapter. The simulation for this model is conducted in the next chapter.

Chapter 6

Simulation of A Multi-Regional CGE Model: A Case for Vietnam's Economy

6.1 General Introduction

In previous chapter, we develop a multi-regional, multi-sector CGE model. The model descriptions particular emphasis on the theoretical structure and the equations linkages used in the CGE framework. The multi-regional CGE model for single country's economy developed which is used to study the regional economic effects of transportation infrastructure investment. The model presents a country's economy with number of sectors, the country divided into various regions. Transportation infrastructure investment makes changes to productivity of the firm's commodity. Applying the CGE model, we explore the impacts of reducing transport costs from transportation infrastructure investment among regions, estimating the effects on the change of commodity flow volume and welfare effect due to both commodity freight transport and passenger flows.

This chapter divided into two parts. First, we make a simulation using Global Trade Analysis Project (GTAP) [95] model to estimate the economic effects of international transportation improvement on Great Mekong Subregion (GMS). The data used for the simulation derived from GTAP Data base version 7. Second, , a preparation of data base for simulation of multiregional CGE model for Vietnam, calibrated to the 2005 interregional input-output which is published in 2009, production and household data, the model is to evaluate the efficiency and distributional effects of transportation improvement. The theoretical model has presented in the previous chapter. The country's

economy model has seen as a standard small open price taking economy model, with CES nested demand, CES and Leontief production functions.

In the next section 6.2, the simulation base on GTAP model is presented and the preparation of data base for simulation of multiregional CGE model with interregional input-output data of Vietnam shown in section 6.3.

6.2 A Simulation base on GTAP model

6.2.1 Overview

The simulation is executed with the numerical software GEMPACK (General Equilibrium Modeling PACKage) is a suite of economic modeling software. It is especially suitable for CGE models, but can handle a wide range of economic behavior. The GTAP model simulation derives this change in the terms of trade in the following manner. (i) First, we aggregate the sectors in the GTAP 7 data according to the classification of goods in Table 6.2. Similarly, we aggregate the regions in the GTAP data into six regions: Vietnam, Cambodia, Lao PDR, Thailand, Myanmar and the rest of the world; (ii) second, we conduct a simulation for transportation improvement between six regions using the GTAP model.

The model in this chapter analyzes the impact of international transportation infrastructure projects on Great Mekong Subregion (GMS) countries. Currently, multiple international transportation infrastructure projects are in progress in the GMS, including cross-border land transportation development, port development. These projects are expected to contribute to the economic development of Vietnam and other GMS members. This model analyzes their impact using the standard GTAP model. It is one of the global computable general equilibrium models with which to estimate the change in economic activities caused by transportation projects.

To stimulate the effective and efficient growth of direct investment and production facilities through the identification of corridors for major transport infrastructure development, the GMS regional economic corridors program was undertaken. This economic corridor approach to sub-regional development was adopted as a fundamental strategy to accelerate the pace of GMS cooperation and to help realize the region's potential. Three corridors were identified as flagship programs under this approach: the North-South Economic Corridor (NSEC), East-West Economic Corridor (EWEC), and

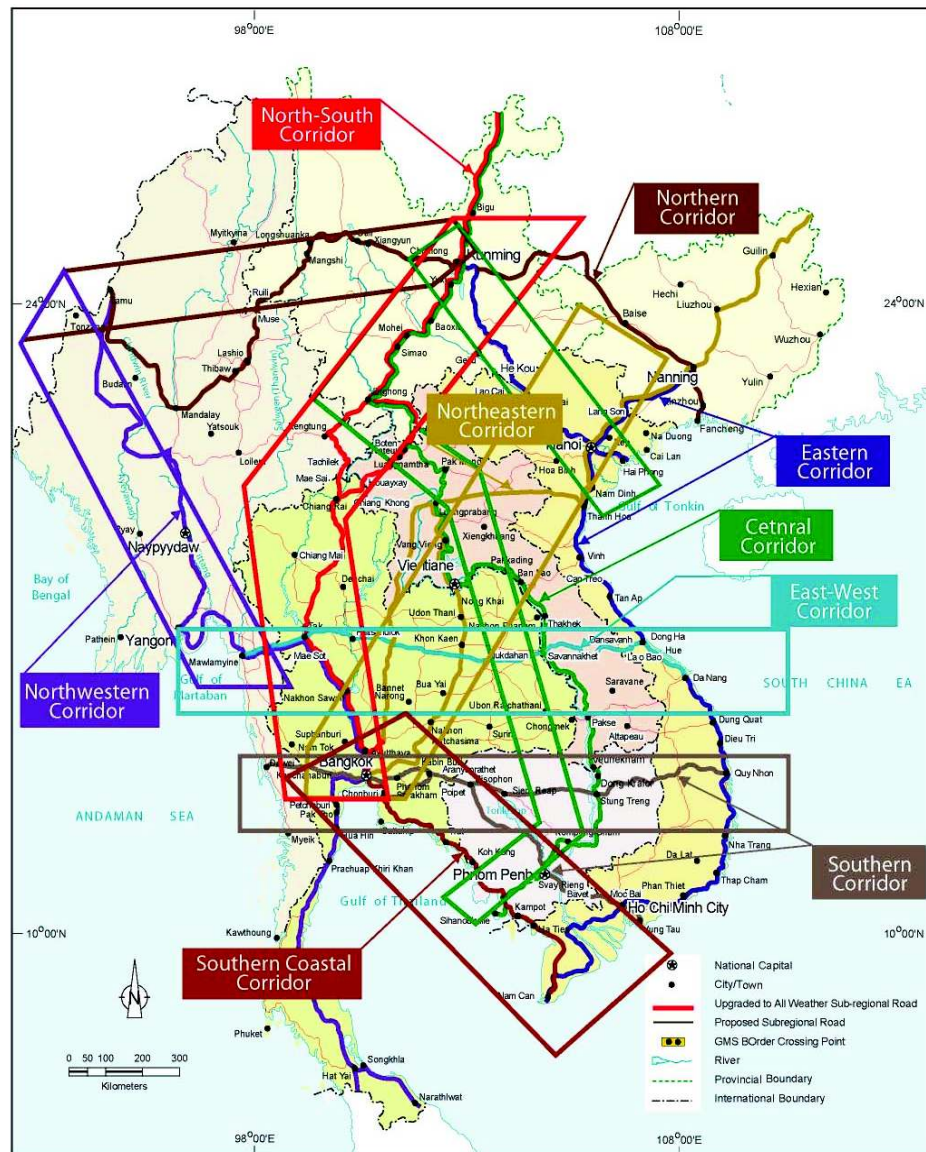

Source: Stone *et al.*, [131]

FIGURE 6.1: GMS economic corridors

Southern Economic Corridor (SEC). In 2007, the GMS ministers agreed to expand the program to a total of nine economic corridors, see Fig. 6.1

A similar approach was adopted by Stone and Strutt [131], who quantified the potential economic impact of land transportation infrastructure development and border crossing facilitation in the GMS. Some of the key linkages between upgraded infrastructure, economic growth, and sectoral responses are explored using a spatial computable general equilibrium framework. The study provides a static view of one-off gains from a conservative estimate of a reduction in transportation costs and improvements in trade facilitation. The results show that GMS members enjoy welfare and GDP growth thanks to the GMS development program. The intra-GMS trade increases while trades between

GMS members and non-GMS countries generally decrease.

6.2.2 Method

The standard GTAP model is used for the scenario analysis with the GTAP database version 7. The model is the global computable general equilibrium models, with which the changes in economic activities caused by transportation projects are estimated. It covers multiple sectors in multiple regions, with the assumptions of perfect competition and constant returns to scale. The database covers a publicly available global database, which contains complete bilateral trade information, transportation, and protection linkages among 113 regions for all 57 commodities in a single year. For analytical simplicity and for the purpose of our analysis, the 113 original regions are aggregated into 6 regions while the 57 original commodities are aggregated into 26 commodities.

The changes in economic activities in each country are estimated by inputting the expected reduction in transportation time and cost into the GTAP model. The GTAP model draws on a set of economic accounts for each country/region, with detailed inter-industry links. Using a global CGE model such as GTAP enables interactions between regions and sectors to be captured within a fully consistent framework. The model we used for this study is comparative, static, and assumes perfectly competitive markets with constant returns to scale, as in the standard version of the GTAP model.

Other standard features of the model are compatible with our model in chapter 5, for example, the behavior of agents; firms maximize profits using the limited resources available in the economy; primary factors of production are combined with intermediate inputs, including imports, to produce final output. Armington elasticities allow differentiation between imports from different countries in the GMS and elsewhere, specifying the extent to which substitution is possible between imports from various sources, as well as substitution between imports and domestic production. When the impact of the infrastructure improvement is simulated, prices and quantities of marketed commodities, along with impacts on incomes and GDP, are all endogenously determined within the model.

The classification of regions and sectors in the model as follows Table 6.1 and Table 6.2.

TABLE 6.1: Regions Classification

Regions	Code	Original regions from GTAP Data Base version 7
1	Vietnam	Vietnam
2	Cambodia	Cambodia
3	Lao PDR	Lao's People Democratic Republic
4	Myanmar	Myanmar
5	Thailand	Thailand
6	ROW	Rest of the World

TABLE 6.2: Sector Classification

No.	Code	Original sectors from GTAP Data Base version 7
1	Paddy	Paddy rice, Wheat
2	other_crops	Vegetables, fruit, nuts, Oil seeds, Sugar cane, Sugar beet, Plant-based fibers, Crops nec, Vegetable oils and fats
3	livesto_pltr	Cereal grains nec, Cattle, Sheep, Goats, Horses, Animal products nec, Meat: Cattle, Sheep, Goats, Horse
4	forestry	Forestry
5	fishfarming	Fishing
6	oil_gas	Oil, Gas, Gas manufacture, distribution
7	mining	Coal, Minerals nec, Mineral products nec
8	proces_rice	Processed rice
9	othe_agrprc	Raw milk, Meat products nec, Dairy products, Sugar, Foods products nec
10	textiles	Wool, Silk-worm cocoons, Textles, Wearing apparel, Leather products
11	Paper	Paper products, Publishing
12	Wood	Wood products
13	rubber	Chemical, rubber, plastic prods
14	non_metalmin	Petroleum, Coal products
15	trans_equpm	Transport equipment nec, Transport nec
16	metal_prod	Ferrous metals, Metals nec, Metal products
17	othe_manuf	Beverages and tobacco products, Motor vehicles and parts, Machinery and equipment nec, Manufactures nec
18	elect_water	Electronic equipment, Electricity, Water
19	construction	Construction
20	transport	Sea transport, Air transport
21	communicatio	Communication
22	Trade	Trade
23	finan_ser	Financial services nec, Insurance
24	public_admin	PubAdmin, Defence, Health, Education
25	hotel_res	Dwellings
26	other_servic	Business services nec, Recreation and other services

6.2.3 Scenarios

Three scenarios are prepared for the analysis. The conditions applied to the transportation in the three scenarios are summarized in Table 6.3.

Scenario 1, 2, 3 assumes the transportation technology coefficient in the GMS is uniformly increased by 20 percent, 30 percent and 50 percent, respectively.

TABLE 6.3: Conditions of transportation improvement in the scenario analysis

No.	Scenarios	Improvement of transport technology coefficient (<i>percent</i>)
1	Scenario	20
2	Scenario	30
3	Scenario	50

Reductions in Transportation Cost The reductions in transportation cost are reflected by changing a technology-related coefficient in the GTAP model. The quantity of goods transported by a specific mode satisfies the following equation in the GTAP model:

$$QXS(i, r, s) = ATMFSD(m, i, r, s) * QTMFSD(m, i, r, s) \quad (6.1)$$

in which $ATMFSD(m, i, r, s) = 1 + atmfsd(m, i, r, s)$

where

- $QXS(i, r, s)$ is the quantity of commodity i imported from region r to region s by mode m ;
- $QTMFSD(m, i, r, s)$ is the quantity of commodity i exported from region r to region s by mode m ;
- $atmfsd(m, i, r, s)$ is the technical change coefficient on transportation of commodity i from region r to region s by mode m .

This reflects the assumption of the iceberg transportation cost, in which transporting a good uses up only some fraction of the good itself rather than using any other resources. The technical coefficient is regarded as the efficiency of transporting goods. In the GTAP model, the variable $atmfsd$ is defined for each commodity, each bilateral trade, and each mode. Then, the increase in $atmfsd$ by 20 percent causes a 20 percent increase in the quantity of commodity imported by the corresponding mode.

6.2.4 Results

Results of Scenario Analysis Table 6.4 presents the changes in real GDP in the GMS countries in the three scenarios with the real GDPs in the baseline scenario in GTAP Data Base version 7. First, GMS members enjoy GDP growth in all scenarios. This means that the international transportation infrastructure development projects in the GMS impart benefit to many countries in the GMS.

TABLE 6.4: Real GDP changes in the GMS countries in the four Scenarios

Scce.	GDP	Vietnam	Cambodia	Lao PDR	Myanmar	Thailand
1*	mil. US\$	43,026	4,884	2,452	7,733	161,698
1	change	1.89%	1.43%	0.63%	0.30%	1.51%
2	change	2.83%	2.14%	0.95%	0.46%	2.26%
3	change	4.72%	3.57%	1.58%	0.76%	3.77%

Note: (*)Base case, author calculated from GTAP Data Base [95].

Second, the estimated results show that the GDP growth rate is higher in Vietnam, Cambodia and Thailand than the GDP growth rate in other two countries. This is mainly because the three countries depend on the other GMS members for their trade more than the others do. This probably indicates that the transportation projects in the GMS contribute to the improvement of the national economy, particularly countries that much involve in the Asian Highway network and have strong trade-relation with neighbor regions.

Third, the GDP growth rate in Vietnam is positive in all three scenarios and gained highest rate compares with other members, especially it reaches at 4.72% in third scenario. This means that the transportation improvement in neighbor countries and region and development of ports in Vietnam contributes highest to the GDP growth.

Finally, Lao PDR and Myanmar have relatively smaller GDP growth rates than other countries. Lao PDR gains 0.63 percent growth in Scenario 1, 0.95 percent in Scenario 2, and 1.58 percent in Scenario 3. Myanmar enjoys only 0.03 percent growth in Scenario 1, 0.46 percent in Scenario 2, and 0.76 percent in Scenario 3. The low growth rate is due to both countries Lao PDR's and Myanmar's trading less with other GMS members than the others do.

Table 6.5 shows the changes in international trades between the GMS members and the rest of the world in Scenarios 1, 2, and 3. First, Table 6.5 shows that in all three scenarios, the trades from one country to neighbor countries increase by a high percentage, for example, the trade from Vietnam to Cambodia; Cambodia to Thailand and Lao PDR to Thailand. This reflects the improvement of cross-border transportation caused by the time reduction in land transportation service.

Second, Table 6.5 shows that in Cambodia and Thailand, more consumption goods are imported from GMS, mainly because the transportation projects improve accessibility from the international market to this both countries. The goods from Cambodia are exported not out of the GMS but to the GMS members, probably because the sharp economic growth in neighbor countries including Thailand and and Vietnam attracts the goods exported from Cambodia.

TABLE 6.5: Changes in interregional trade between GMS member and ROW in the three Scenarios

Scenario 1	Vietnam	Cambodia	Lao PDR	Myanmar	Thailand	ROW
Vietnam	-	4.25%	0.24%	-2.11%	0.75%	1.84%
Cambodia	3.93%	-	-1.05%	-0.14%	9.07%	0.95%
Lao PDR	-0.84%	0.06%	-	-1.28%	5.18%	0.02%
Myanmar	0.65%	5.82%	-0.88%	-	-2.54%	2.68%
Thailand	2.70%	1.68%	2.84%	1.52%	-	1.23%
ROW	2.75%	2.25%	0.65%	2.12%	1.74%	1.34%
Scenario 2	Vietnam	Cambodia	Lao PDR	Myanmar	Thailand	ROW
Vietnam	-	6.37%	0.36%	-3.17%	1.13%	2.76%
Cambodia	5.90%	-	-1.57%	-0.20%	13.60%	1.42%
Lao PDR	-1.26%	0.13%	-	-1.92%	7.77%	0.03%
Myanmar	0.98%	8.74%	-0.88%	-	-3.82%	4.02%
Thailand	4.05%	2.53%	4.26%	2.28%	-	1.85%
ROW	4.12%	3.37%	0.98%	3.18%	2.60%	2.00%
Scenario 3	Vietnam	Cambodia	Lao PDR	Myanmar	Thailand	ROW
Vietnam	-	10.62%	0.60%	-5.28%	1.88%	4.60%
Cambodia	9.84%	-	-2.63%	-0.34%	22.67%	2.37%
Lao PDR	-2.11%	0.19%	-	-3.21%	12.94%	0.05%
Myanmar	1.63%	14.56%	-1.75%	-	-6.36%	6.70%
Thailand	6.75%	4.21%	7.10%	3.80%	-	3.08%
ROW	6.87%	5.62%	1.64%	5.30%	4.34%	3.34%

Finally, Table 6.5 shows that the trades between the GMS and the ROW increase. However, the more consumption goods are imported from ROW to GMS than exported to ROW.

Tables 6.6, 6.7 and 6.8 show the estimated changes in output by industry in the GMS members in Scenarios 1, 2, and 3. Tables 6.6, 6.7 and 6.8 show that the change in output in Vietnam is the highest among the GMS members in all scenarios. This is supported mainly by the development of processing rice and wood industries reach 18.72 percent and 13.17 percent, respectively in scenario 3. Other two industries' output should be mentioned here are the mining and forestry increase by 8.82 percent and 8.34 percent, respectively, while the outputs in oil, gas decrease by 12.16 percent.

The results mean that the industrial structure in Vietnam is changed by the international transportation project to wood and timber industries and the Tables 6.6, 6.7 and 6.8 shows that the output in Cambodia decreases at the highest rate in Scenario.

TABLE 6.6: Estimated changes in output by industry in the Scenario 1

Industry	Vietnam	Cambodia	Lao PDR	Myanmar	Thailand	ROW
paddy	2.71%	0.24%	0.86%	0.67%	3.93%	-0.31%
other_crops	-0.99%	1.03%	0.28%	0.45%	2.53%	-0.25%
livesto_pltr	2.08%	1.20%	0.45%	0.51%	1.86%	-0.04%
forestry	3.34%	0.97%	2.43%	3.62%	0.93%	-0.07%
fishfarming	1.99%	1.21%	0.20%	2.66%	1.73	-0.03%
oil_gas	-4.86%	-5.18%	1.38%	-3.49%	-3.25%	-0.72%
mining	3.53%	-6.10%	-0.92%	1.49%	1.05%	-0.30%
proces_rice	7.49%	0.48%	0.73%	0.66%	4.37%	-0.63%
othe_agrprc	0.76%	-0.41%	0.12%	0.36%	2.00%	-0.06%
textiles	2.39%	1.81%	0.43%	3.36%	-0.33%	-0.11%
paper	-0.28%	-3.81%	-3.50%	-0.99%	1.45%	-0.13%
wood	5.27%	1.40%	1.84%	4.18%	1.96%	-0.43%
rubber	-0.21%	-1.38%	11.37%	2.20%	1.80%	-0.23%
non_metalmin	-3.21%	-0.40%	-1.00%	-1.90%	-1.03%	-1.23%
trans_equpm	0.20%	-2.52%	-1.63%	-1.16%	-1.61%	-1.06%
metal_prod	-1.06%	-3.69%	0.68%	-2.12%	1.59%	-0.28%
othe_manuf	0.33%	-1.44%	-1.11%	-1.28%	0.62%	-0.10%
elect_water	0.49%	-0.90%	0.03%	0.06%	-1.05%	-0.12%
construction	1.64%	0.29%	-0.27%	-0.09%	0.51%	-0.07%
transport	-3.32%	-2.95%	-4.56%	-1.97%	-5.75%	-5.31%
communicatio	-1.13%	-1.99%	0.64%	1.26%	1.04%	-0.02%
trade	1.00%	1.06%	0.73%	0.84%	1.57%	0.02%
finan_ser	-0.07%	0.31%	0.40%	1.36%	1.35%	0.00%
public_admin	2.11%	1.37%	0.41%	0.30%	1.96%	0.04%
hotel_res	3.18%	2.71%	1.38%	1.13%	2.99%	0.09%
other_servic	1.06%	0.60%	0.39%	0.57%	0.43%	-0.03%
Total	24.43%	-16.10%	11.77%	12.70%	22.63%	-11.38%

6.2.5 Discussion

This GTAP-based model analyzed the effects of the international transportation projects on the GMS countries' economy. The results show that they will surely accelerate the development of Vietnam and the other GMS members by enhancing economic integration among them. The results indicate that the economic growth in Vietnam is particularly significant. More imports become available in Vietnam because the market price of imports decreases, both from other GMS members and from the rest of the world. This enhances production and consumption in the country.

In addition, the exports from Vietnam become more competitive in foreign markets due to the reductions in time and cost.

TABLE 6.7: Estimated changes in output by industry in the Scenario 2

Industry	Vietnam	Cambodia	Lao PDR	Myanmar	Thailand	ROW
paddy	4.06%	0.36%	1.29%	1.01%	5.89%	-0.47%
other_crops	-1.49%	1.55%	0.42%	0.68%	3.79%	-0.37%
livesto_pltr	3.12%	1.80%	0.67%	0.77%	2.79%	-0.06%
forestry	5.00%	1.45%	3.65%	5.43%	1.39%	-0.11%
fishfarming	2.98%	1.81%	0.29%	3.99%	2.59	-0.04%
oil_gas	-7.29%	-7.78%	2.07%	-5.23%	-4.88%	-1.08%
mining	5.29%	-9.15%	-1.38%	2.23%	1.58%	-0.45%
proces_rice	11.23%	0.71%	1.09%	0.99%	6.55%	-0.94%
othe_agrprc	1.15%	-0.61%	0.19%	0.54%	3.01%	-0.10%
textiles	3.59%	2.71%	0.64%	5.03%	-0.49%	-0.16%
paper	-0.42%	-5.71%	-5.24%	-1.48%	2.18%	-0.20%
wood	7.90%	2.10%	2.76%	6.27%	2.94%	-0.65%
rubber	-0.32%	-2.07%	17.06%	3.30%	2.70%	-0.35%
non_metalmin	-4.81%	-0.61%	-1.50%	-2.85%	-1.55%	-1.85%
trans_equpm	0.30%	-3.78%	-2.45%	-1.74%	-2.42%	-1.59%
metal_prod	-1.59%	-5.53%	1.03%	-3.17%	2.38%	-0.42%
othe_manuf	0.49%	-2.16%	-1.66%	-1.93%	0.93%	-0.16%
elect_water	0.74%	-1.35%	0.04%	0.09%	-1.58%	-0.18%
construction	2.46%	0.43%	-0.41%	-0.14%	0.77%	-0.10%
transport	-4.98%	-4.42%	-6.83%	-2.95%	-8.63%	-7.97%
communicatio	-1.69%	-2.99%	0.96%	1.90%	1.56%	-0.03%
trade	1.49%	1.60%	1.09%	1.27%	2.35%	0.03%
finan_ser	-0.10%	0.46%	0.60%	2.04%	2.03%	0.00%
public_admin	3.17%	2.06%	0.62%	0.45%	2.94%	0.06%
hotel_res	4.77%	4.06%	2.07%	1.70%	4.49%	0.14%
other_servic	1.59%	0.90%	0.59%	0.86%	0.65%	-0.05%
Total	36.64%	-24.15%	17.66%	19.05%	33.95%	-17.07%

6.3 A Simulation with Vietnam IRIO Data

6.3.1 Introduction

In the previous section we made a simulation using GTAP model to estimate the economic effects of international transportation improvement on Great Mekong Subregion. The data used for the simulation derived from GTAP Data base version 7. The results show that they will surely accelerate the development of Vietnam and the other GMS members by enhancing economic integration among them. The results indicate that the economic growth in Vietnam is particularly significant.

This section introduces a simulation for multiregional computable general equilibrium model of the Vietnamese economy. Calibrated to the 2005 interregional input-output

TABLE 6.8: Estimated changes in output by industry in the Scenario 3

Industry	Vietnam	Cambodia	Lao PDR	Myanmar	Thailand	ROW
paddy	6.77%	0.60%	2.15%	1.68%	9.82%	-0.78%
other_crops	-2.49%	2.58%	0.70%	1.13%	6.32%	-0.62%
livesto_pltr	5.20%	2.99%	1.11%	1.28%	4.65%	-0.09%
forestry	8.34%	2.42%	6.09%	9.05%	2.32%	-0.18%
fishfarming	4.97%	3.02%	0.49%	6.64%	4.32	-0.07%
oil_gas	-12.16%	-12.96%	3.45%	-8.71%	-8.13%	-1.80%
mining	8.82%	-15.24%	-2.29%	3.72%	2.63%	-0.75%
proces_rice	18.72%	1.19%	1.82%	1.65%	10.92%	-1.57%
othe_agrprec	1.91%	-1.02%	0.31%	0.89%	5.01%	-0.16%
textiles	5.98%	4.52%	1.06%	8.39%	-0.82%	-0.27%
paper	-0.70%	-9.52%	-8.74%	-2.47%	3.64%	-0.33%
wood	13.17%	3.50%	4.60%	10.45%	4.90%	-1.09%
rubber	-0.53%	-3.46%	28.43%	5.50%	4.50%	-0.58%
non_metalmin	-8.01%	-1.01%	-2.50%	-4.75%	-2.59%	-3.08%
trans_equpm	0.51%	-6.30%	-4.08%	-2.90%	-4.04%	-2.64%
metal_prod	-2.66%	-9.22%	1.71%	-5.29%	3.96%	-0.70%
othe_manuf	0.82%	-3.60%	-2.76%	-3.21%	1.55%	-0.26%
elect_water	1.23%	-2.25%	0.07%	0.16%	-2.63%	-0.29%
construction	4.10%	0.72%	-0.69%	-0.23%	1.28%	-0.17%
transport	-8.30%	-7.37%	-11.39%	-4.92%	-14.38%	-13.28%
communicatio	-2.82%	-4.98%	1.60%	3.16%	2.60%	-0.05%
trade	2.49%	2.66%	1.81%	2.11%	3.92%	0.04%
finan_ser	-0.16%	0.77%	1.00%	3.41%	3.39%	-0.01%
public_admin	5.29%	3.43%	1.03%	0.75%	4.90%	0.10%
hotel_res	7.94%	6.77%	3.45%	2.84%	7.48%	0.23%
other_servic	2.65%	1.50%	0.98%	1.43%	1.08%	-0.08%
Total	61.07%	-40.25%	29.43%	31.75%	56.58%	-28.45%

which is published in 2009, production and household data, the model is to evaluate the efficiency and distributional effects of transportation improvement. The theoretical model has presented in the previous chapter. The country's economy model has seen as a standard small open price taking economy model, with CES nested demand, CES and Leontief production functions.

On the production side, the model includes 28 sectors. The data for these sectors are aggregated from the latest available 2005 Interregional Input-Output Table for Vietnam¹. On the consumption side, the data come from the recent Vietnam Living Standards Survey (VLSS) for 2008. Eight region household types are identified. Several other sources of data are also used for constructing the benchmark data set for the model.

¹GSO, MPI Interregional Input-Output Table 2005

One of the novelties in the CGE models for Vietnam is to deal with aggregating, updated data and especially transportation data.

6.3.2 The Model

CGE model including 28 commodity sectors as a standard small open price taking economy model, we adopted CES nested demand and CES production functions, substitutable intermediate transactions appear on the production side. On the consumption side, the data come from the recent Vietnam Living Standards Survey [132]. Eight regional household groups are identified. Several other sources of data are also used for constructing the benchmark data set for the model. We use Vietnamese data for 2005 to calibrate the model.

As noted in the previous chapters, the regional effects of transportation infrastructure investment can present significantly because of large differences in regional freight volume, passenger flows, and trade, but the previous CGE studies in Vietnam mainly focused on poverty reduction, there have given little attention to the regional effects of interregional trade, the change in commodity and human movements. For a better understanding of transportation infrastructure investment policy, it is then of great importance to analyze regional effects. In addition, the expansion of regional disparities in Vietnam also increases the importance of the analysis of the regional effects of trade liberalization. Regional disparity in this context is the economic disparity between large and local regions caused by the concentration of economic activity in large regions and the outflow of employment from local regions.

6.3.3 Structure and Specifications of the Model

The multiregional CGE model provided in this chapter is a small/price taking open economy model as stated above. There are 3 agents that form the economy; Household (representative for regions), Industry (28 sectors, i.e. industries and services), and Rest of the World (ROW). The households own all the factors of production including labour, capital and labour factors specific to industries (immobile across region). The endowments of each factor remain unchanged in all model simulations.

There are two approaches namely top-down and bottom-up. The first one, the top-down approach where a nationwide CGE model first derives the effects on the nation as a whole, and then the nationwide effects are broken down to numerous of regional effects. Meanwhile, bottom-up approach where a region-level CGE model is constructed

at the start. There are advantages and disadvantages with both approaches, and it is not easy to determine which approach is better, but, in terms of the structure of the model, the second approach is clearly superior. We developed model used a bottom-up approach where a region-level CGE model is constructed at the start in which the model with individual regions are explicitly incorporated.

One of the novelties of our CGE model lies in incorporating time resources in the production factors, as well as mobile capital and labor, to eliminate problems of specialization. In reality, for each production sector there is a component of factors used that can be considered as fixed during the taken period of time, and another component is mobile across sectors. We have very little information on this subject. What we do until now is to use the depreciation data available in the 2007 I-O Table and other studies to make our estimate on the fixed component of factors.

In our CGE model there is no investment as ours is a static model. All the factors are assumed to belong to the households. We assume full employment of all the factors of production and compute a Walrasian general equilibrium model. Each household gets returns from employment of the factors and pays the income. Households spend all their disposable income to purchase consumption goods for present.

The CGE model includes 28 industries (commodity sectors) aggregated from the latest available 2005 sector IO Table (2007) and IRIO Table 2005 (2007) for Vietnam. In the model eliminated transport sector: transport cost added in to the process of freight transport and passenger business trip.

Thus, all the industries use the primary factors supplied by households and intermediate input goods, the latter come either from the sectors themselves or from the ROW (imported intermediate input goods). The sectors, in turn, pay wages for factors they use to the households and transport cost for freight transport and passenger business trip.

6.3.3.1 Production

As noted above, the model incorporates 28 production sectors aggregated from sectors identified in the IRIO Table 2007 for Vietnam. The list of the model sectors with its corresponding sectors in the IO Table is given in Table 6.9.

TABLE 6.9: Sectoral Aggregation Used in the Multi-regional CGE model

Model Sector	
1	Paddy
2	Other crops
3	Livestock & Poultry
4	Forestry
5	Fish Farming
6	Fishery
7	Oil & gas
8	Mining
9	Processed seafood
10	Processed Rice
11	Other Agricultural Processing
12	Textiles
13	Paper
14	Wood
15	Rubber
16	Non-Metallic Mineral Products
17	Transport Equipment
18	Metal Products
19	Other Manufacturing
20	Electricity & Water
21	Construction
22	Commercial-Transport
23	Communication
24	Trade
25	Financial services
26	Public Administration
27	Hotels & Restaurants
28	Other Services
29	Self-Transportation

Note: Vietnam IO Table 2005, GSO [103].

The choice of the sectoral aggregation is to keep the main structure of the Vietnamese economy. Each sector of the model produces goods using both primary factors (including capital, labour, transport services), and intermediate (domestically produced on imported) inputs.

The production functions we use are in four nested constant elasticity of substitution (Leontief, CES) form, see Fig.6.2, recall Fig.5.2. At the bottom level primary factors are aggregated by CES function to give composite factor inputs. Similarly, all intermediate goods including imported are nested into composite intermediate goods inputs by CES function. Intermediate goods and factor inputs are then aggregated follow Leontief function at the upper level of the production function to give final output. Factor and intermediate good demands are determined from the first order conditions of cost minimization, see Shoven and Whalley, 1992 [51].

6.3.3.2 Household demand side

In the model, 8 household groups are identified according to the classification (by the regional level of expenditure) in the VLLS 2008. We decompose these quintile groups into 8 representative regional households using information from the GSO survey data. To represent the demand side, we assume a representative household in each region. The utility of the household is a CES type function of consumption. In addition, consumption is a CES type function of individual consumption goods. Figure 6.2 represents the utility function. In the simulations conducted later, we calculate the welfare effects of transportation improvement. These welfare effects are the effects on the utility of

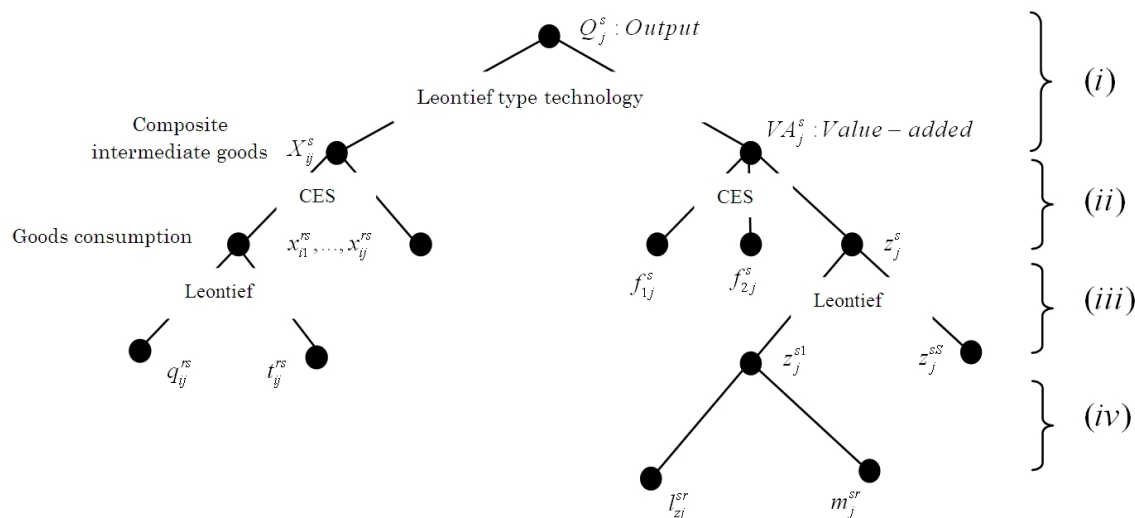

FIGURE 6.2: Production technology.

the representative household. The representative household supplies primary factors to industry and earns factor income. We assume that the endowment of primary factors is an exogenous constant.

6.3.3.3 Transportation

Transportation data estimated from interregional IO table of Vietnam. Both self-transportation services (identified as transportation industries within the Vietnam economy IO accounts) and commercial-transportation services (not separately identified as transportation in the I-O accounts) are derived for each sector in order to provide a more complete picture of the economic impact of transportation on the Vietnamese economy. The detail of transportation satellite accounts have been conducted in the chapter 4.

6.3.3.4 International trade

We assume only one foreign region as rest of the world (ROW) to assume a small country. The terms of trade in our model are determined exogenously, we use the following approach to derive change in the terms of trade. As in other CGE models, we use the Armington assumption for each region. Armington aggregation is through a two-stage CES function in Figure 3. First, domestic goods from eight regions (including the own region) are aggregated into composite domestic goods through a CES function. Second, the import goods and composite domestic goods are aggregated. Note that standard trade CGE models like the GTAP model aggregate imports from different regions because they have imports from multiple regions, while our model aggregates

domestic supply from different domestic regions. Aggregated Armington goods are used for the consumption and intermediate inputs in each region.

6.3.4 Data

To construct the bottom-up multi-regional CGE model, it is necessary to obtain Social Accounting Matrix (SAM) data for individual regions as well as interregional trade data. For the bottom-up approach is very data demanding. In term of interregional trade data, our study uses IRIO Data for Vietnam, 2005 provided by Ministry of Planning and Investment (2009). The original IRIO data include 28 sector goods and 8 regions, which we keep the number of sectors and regions remain unchanged, however, we derived and disaggregated both self-transportation and commercial-transportation from existing transport sector. For international trade between domestic regions and foreign regions, it is difficult to create a model with model with multiple domestic regions and multiple foreign regions because of huge data demanding. Hence, our study assumes a model with exogenous terms of trade.

Data requirements consist of IRIO table for Vietnam, transportation accounts data, and a set of technological and behavioral parameters governing the responsiveness of the economy to exogenous changes.

6.3.4.1 Primary input factor data

The data on primary factors are based on the IO table. Payment to labor in the individual sector is the sum of "consumption expenditure outside households" and "compensation of employees". Similarly, payment to capital is derived by summing "operating surplus" and "depreciation of fixed capital".

6.3.4.2 Elasticity data

The complete elasticity data set includes several sets of elasticities of substitution in production, consumption and trade; elasticities of transformation in multiproduct industries; expenditure elasticities of demand; and elasticities of product and factor supply with respect to price. Estimates of the complete parameter set do not exist for any country, let alone for Vietnam. The standard approach in CGE modeling has been to assume values where estimates are unavailable, or in some cases to "borrow" them from estimates obtained in arguably similar economies. For many components of this data set, data constraints require a similar strategy.

TABLE 6.10: Definition of set

Notation	Description	Program
i, j	Index of sectors and goods region s	
r, s	Index of regions in Vietnam	
PAD	Set for sector PAD (Paddy)	

TABLE 6.11: Activity level

Notation	Description	Program
Q_j^s	Total output of firms j in region s	
U^s	The utility	
L_{zj}^{sr}, T^{sr}	Transport service and total working hour	
c_j^s	Consumption of goods j region s	

TABLE 6.12: Price index

Notation	Description	Program
p_j^s	Price index of goods j in region s	
p_{ij}^s	Price index of goods i in sector j of region s	
p_{zj}^s	Price index of business trip in sector j of region s	
p_{hj}^s	Price index of goods j of household in region s	
p_{zj}^s	Price index of composite z_j^s	
uc_{Vj}^s	Unit cost of value-added of sector j region s	
p_j^{Ms}	Price index of import in sector j region s	
p_j^{Ds}	Price index of domestic in sector j region s	

It will also be possible to obtain estimates of the responsiveness of households to product and factor market shocks from the VLSS data set. Information on household behavior from the current VLSS can be derived only from cross-sectional estimates, as the most recently released (2002) survey round does not build on the households sampled in earlier rounds (1993, 1998). However, subsequent VLSS round (2004) resurveyed some households from the 2002 round, so it is feasible to use panel data estimators to build in more detailed econometric information on household behavior with respect to product markets, factor (especially labor) markets.

6.3.5 Simulation

We define necessary notations for model simulation.

6.3.6 Benchmark Data, Parameters and Elasticities

The benchmark data set used in the model calibration has been constructed for the base year 2005. The latest I/O Table 2005 and the VLSS-2006, 2008, Statistical Year book

TABLE 6.13: Elasticity of Substitution

Notation	Description	Program
σ_1	Elasticity of substitution between intermediate inputs	
σ_2	Elasticity of substitution among primary factors	
σ_3	Elasticity of substitution business trips	
σ_4	Elasticity among aggregate consumption goods	
σ_5	Elasticity among consumption goods from other regions	
ρ_j^M	Elasticity of substitution among import varieties	
ρ_j^M	Elasticity of substitution among export varieties	

TABLE 6.14: Firm's behavior

Parameters	Source	Calculation
σ_{1j} :elasticity of substitution	GTAP data, exogenous variables, or, apply from CHAN & Whalley	
a_{ij}^s :input coefficients	Input-output table	$a_{ij}^s = \frac{x_{ij}^s}{Q_j^s}$
a_{vj}^s :input coefficients	Input-output table	$a_{vj}^s = \frac{VA_{ij}^s}{Q_j^s}$
δ_{kj}^s :input coefficients	Input-output table	$\delta_{kj}^s = \frac{rk_j^s \frac{1}{\sigma_{1j}}}{rk_j^s \frac{1}{\sigma_{1j}} + w^s l_j^s \frac{1}{\sigma_{1j}} + p_{zj}^s z_j^s \frac{1}{\sigma_{1j}}}$
δ_{lj}^s :input coefficients	Input-output table	$\delta_{lj}^s = \frac{w^s l_j^s \frac{1}{\sigma_{1j}}}{rk_j^s \frac{1}{\sigma_{1j}} + w^s l_j^s \frac{1}{\sigma_{1j}} + p_{zj}^s z_j^s \frac{1}{\sigma_{1j}}}$
δ_{zj}^s :input coefficients	Input-output table	$\delta_{zj}^s = \frac{p_{zj}^s z_j^s \frac{1}{\sigma_{1j}}}{rk_j^s \frac{1}{\sigma_{1j}} + w^s l_j^s \frac{1}{\sigma_{1j}} + p_{zj}^s z_j^s \frac{1}{\sigma_{1j}}}$
φ_j :input coefficients	Input-output table	$\varphi_j = \frac{VA_j^s}{\left(rk_j^s \frac{\sigma_{1j}-1}{\sigma_{1j}} + w^s l_j^s \frac{\sigma_{1j}-1}{\sigma_{1j}} + p_{zj}^s z_j^s \frac{\sigma_{1j}-1}{\sigma_{1j}} \right)^{\frac{\sigma_{1j}}{\sigma_{1j}-1}}}$
T^{sr} :total working hour	Statistics data from GSO	Exogenous variables
a_{2l}^{sr} :input coefficients	Input-output table	$a_{2l}^{sr} = \frac{l_{ij}^{sr}}{z_j^{sr} T^{sr}}$
a_{2m}^{sr} :input coefficients	Input-output table	$a_{2m}^{sr} = \frac{m_j^{sr}}{z_j^{sr}}$
σ_{2ij} :input coefficients	GTAP data, exogenous variables	
δ^{rs} :input coefficients	Input-output table	$\delta^{rs} = \frac{p_{ij}^{rs} x_{ij}^{rs} \frac{1}{\sigma_{2ij}}}{\sum_i p_{ij}^{rs} x_{ij}^{rs} \frac{1}{\sigma_{2ij}}}$
a_{3ij}^{rs} :input coefficients	Input-output table	$\delta^{rs} = \frac{q_{ij}^{rs}}{x_{ij}^{rs}}$
a_{ijt}^{rs} :input coefficients	Input-output table	$a_{ijt}^{rs} = \frac{t_{ij}^{rs}}{x_{ij}^{rs}}$
q_{ij}^{rs} :input coefficients	Input-output table	$a_{ijt}^{rs} = \frac{t_{ij}^{rs}}{x_{ij}^{rs}}$
t_{ij}^{rs} :net passenger flow	Input-output table	Exogenous variables
m_j^{sr} :road traffic	Input-output table	Exogenous variables

2007, 2008, 2009, GTAP database version 7, serve as our main data source.

TABLE 6.15: Classification of regions aggregated from the 63 provinces in 2005 IO table

Regions	Symbol	Description	Regions aggregated from the original 63 provinces in IO table
1 Region I	NOW	Northwestern	Ha Giang, Cao Bang, Bac Kan, Tuyen Quang, Lao Cai, Yen Bai, Thai Nguyen, Lang Son, Bac Giang, Phu Tho
2 Region II	NOE	Northeastern	Lai Chau, Dien Bien, Son La, Hoa Binh
3 Region III	RRD	Red River Delta	Ha Noi, Quang Ninh, Vinh Phuc, Bac Ninh, Hai Duong, Hai Phong, Hung Yen, Thai Binh, Ha Nam, Nam Dinh, Ninh Binh
4 Region IV	NCC	North Central Coast	Thanh Hoa, Nghe An, Ha Tinh, Quang Binh, Quang TriThua Thien Hue
5 Region V	SCC	South Central Coast	Da Nang, Quang Nam, Quang Ngai, Binh Dinh, Phu Yen, Khanh Hoa, Ninh Thuan, Binh Thuan
6 Region VI	CEH	Central Highlands	Kon Tum, Dak Lak, Gia Lai, Dak Nong, Lam Dong
7 Region VII	SOE	Southeastern	Binh Phuoc, Tay Ninh, Binh Duong, Dong Nai, Ba Ria- Vung Tau, Ho Chi Minh City
8 Region VIII	MRD	Mekong River Delta	Long An, Tien Giang, Ben Tre, Tra Vinh, Vinh Long, Dong Thap, An Giang, Kien Giang, Can Tho, Hau Giang, Soc Trang, Bac Lieu, Ca Mau

TABLE 6.16: Classification of sectors and goods

	Symbol	Description	Sectors in the Original IO table
1	PAD	Paddy	Paddy rice
2	OCR	Other crops	Wheat, Vegetables, fruit, nuts, Oil seeds, Sugar cane, sugar beet, Crops nec,
3	LVP	Livestocks & Poultry	Meat products nec, Animal products nec, Cereal grains nec, Bovine cattle, sheep and goats, horses, Bovine meat products, Raw milk, Dairy products
4	FOR	Forestry	Forestry
5	FIF	Fish Farming	Fishing Farm
6	FIS	Fishery	Fishing
7	O_G	Oil & gas	Oil, Gas
8	MIN	Mining	Minerals nec, Coal, Mineral products nec
9	PRS	Processed seafood	Processed preserved fishery and by-products
10	PRR	Processed Rice	Processed rice,
11	OAP	Other Agricultural Processing	Vegetable oils and fats, Sugar, Food products nec
12	TEX	Textiles	Textiles, Wearing apparel, Leather products, Wool, Silk-worm cocoons, Plant-based fibers
13	PPP	Paper	Paper products, publishing
14	WOO	Wood	Wood products
15	RUB	Rubber	Chemical, rubber, plastic products
16	NMM	Non-Metallic Mineral Products	Petroleum, coal products
17	TRE	Transport equipment	Transport equipment nec
18	MET	Metal Products	Metals nec, Metal products, Ferrous metals
19	OMN	Other Manufacturing	Beverages and tobacco products, Motor vehicles and parts, Machinery and equipment nec, Manufactures nec, Gas manufacture, distribution
20	E.W	Electricity & Water	Electricity, Water, Electronic equipment
21	CNS	Construction	Construction
22	CTR	Commercial-transportation	New transport sector introduced for the model
23	CMN	Communication	Communication
24	TRA	Trade	Trade
25	FIN	Financial servies	Financial services nec
26	PUA	Public Administration	Public Administration, Defense, Education, Health
27	HOR	Hotels & Restaurants	Dwellings
28	SER	Other Services	Recreational and other services, Business services nec, Insurance
29	STR	Self-transportation	New transport sector introduced for the model

TABLE 6.17: Substitution parameter between primary factors in the CES value-added nest of the nested production structure of the sector in all region

	Symbol	Description	Value
1	PAD	Paddy	0.23
2	OCR	Other crops	0.27
3	LVP	Livestocks & Poultry	0.39
4	FOR	Forestry	0.20
5	FIF	Fish Farming	0.20
6	FIS	Fishery	0.20
7	O_G	Oil & gas	0.31
8	MIN	Mining	0.77
9	PRS	Processed seafood	1.12
10	PRR	Processed Rice	1.12
11	OAP	Other Agricultural Processing	1.04
12	TEX	Textiles	1.24
13	PPP	Paper	1.26
14	WOO	Wood	1.26
15	RUB	Rubber	1.26
16	NMM	Non-Metallic Mineral Products	1.26
17	TRE	Transport equipment	1.62
18	MET	Metal Products	1.26
19	OMN	Other Manufacturing	1.25
20	E_W	Electricity & Water	1.26
21	CNS	Construction	1.40
22	CTR	Commercial-Transportation	1.68
23	CMN	Communication	1.26
24	TRA	Trade	1.68
25	FIN	Financial services	1.26
26	PUA	Public Administration	1.26
27	HOR	Hotels & Restaurants	1.26
28	SER	Other Services	1.26
29	STR	Self-Transportation	1.68
	TOT	Total	30.26

Author calculated base on GTAP version 7

TABLE 6.18: Production side elasticity of substitution in the Model

Industry	Elasticities of substitution between inputs	Elasticities of substitution between composite inputs (factor input and good input)
	2	3
1 Paddy	0.300	0.200
2 Other crops	0.300	0.200
3 Livestocks & Poultry	0.300	0.200
4 Forestry	0.300	0.200
5 Fish Farming	0.300	0.200
6 Fishery	0.300	0.200
7 Oil & gas	0.450	0.300
8 Mining	0.450	0.300
9 Processed seafood	0.680	0.453
10 Processed Rice	0.600	0.400
11 Other Agricultural Processing	0.300	0.200
12 Textiles	0.530	0.353
13 Paper	0.530	0.353
14 Wood	0.530	0.353
15 Rubber	0.600	0.400
16 Non-Metallic Mineral Products	0.600	0.400
17 Transport equipment	0.530	0.353
18 Metal Products	0.530	0.353
19 Other Manufacturing	0.300	0.200
20 Electricity & Water	0.300	0.200
21 Construction	0.300	0.200
22 Commercial-Transportation	0.300	0.200
23 Comunication	0.300	0.200
24 Trade	0.600	0.400
25 Financial servies	0.600	0.400
26 Public Administration	0.300	0.200
27 Hotels & Restaurants	0.600	0.400
28 Other Services	0.300	0.200
29 Self-Transportation	0.300	0.200

Note: Author applied and estimated based on Chia, Wahba and Whalley (1992) [133] and Chan, Nguyen and T. K. Dung (2001) [99]

TABLE 6.19: Population and Labor Structure

	Region	Labour*	Annual in- come**	Annual consump- tion expen- diture per capita**
1	NOW	2,563.1	3,188.4	3,009.6
2	NOE	9,354.7	4,558.8	3,898.8
3	RRD	18,028.3	5,858.4	5,012.4
4	NCC	10,604.8	3,805.2	3,308.4
5	SCC	7,049.8	4,978.8	4,396.8
6	CEH	4,757.9	4,682.4	3,855.6
7	SOE	13,491.7	9,996.0	7,492.8
8	MRD	17,256.0	5,653.2	4,513.2
	Vietnam	83,106.3	42,721.2	35,487.6

Source: Vietnam Living Standards Survey [132]; Statistical Year Books [103]

Note:

* thousands persons

** thousands VND

TABLE 6.20: Labor and Wage rate

	Region	Working hour per week	Week in year	Total hours	Annual income*	Wage rate
1	NOW	29.4	52.0	1,528.8	3,188.4	2.1
2	NOE	31.1	52.0	1,617.2	4,558.8	2.8
3	RRD	31.4	52.0	1,632.8	5,858.4	3.6
4	NCC	29.7	52.0	1,544.4	3,805.2	2.5
5	SCC	30.6	52.0	1,591.2	4,978.8	3.1
6	CEH	31.7	52.0	1,648.4	4,682.4	2.8
7	SOE	41.6	52.0	2,163.2	9,996.0	4.6
8	MRD	28.4	52.0	1,476.8	5,653.2	3.8

Note: Author calculated base on VLSS 2006, 2008 [132]; Statistical Year Book 2006,2007,2008 [103]

Note: * thousands VND

TABLE 6.21: Consumption side Elasticities of Substitution Used in the Model

	Household type	Elasticities of substitution used in consumption level 1	Elasticities of substitution used in consumption level 2
		1	2
1	HH_NOW	1.260	1.890
2	HH_NOE	1.260	1.890
3	HH_RRD	1.260	1.890
4	HH_NCC	1.260	1.890
5	HH_SCC	1.260	1.890
6	HH_CEH	1.260	1.890
7	HH_SOE	1.260	1.890
8	HH_MRD	1.260	1.890

Note: Author applied and estimated based on Chia, Wahba and Whalley (1992) [133] and Chan, Nguyen and T. K. Dung (2001) [99]

TABLE 6.22: Armington Elasticities

	Symbol	Description	ESUBD	ESUBM
1	PAD	Paddy	4.75	9
2	OCR	Other crops	2.45	5.18
3	LVP	Livestocks & Poultry	2.22	4.83
4	FOR	Forestry	2.5	5
5	FIF	Fish Farming	1.25	2.5
6	FIS	Fishery	1.25	2.5
7	O_G	Oil & gas	6.94	14.25
8	MIN	Mining	2.4	4.2
9	PRS	Processed seafood	2.6	5.2
10	PRR	Processed Rice	2.6	5.2
11	OAP	Other Agricultural Processing	2.64	5.24
12	TEX	Textiles	3.8	7.59
13	PPP	Paper	2.95	5.9
14	WOO	Wood	3.4	6.8
15	RUB	Rubber	3.3	6.6
16	NMM	Non-Metallic Mineral Products	2.1	4.2
17	TRE	Transport equipment	2.4	6.62
18	MET	Metal Products	3.55	7.23
19	OMN	Other Manufacturing	3.33	6.96
20	E_W	Electricity & Water	3.73	8.71
21	CNS	Construction	1.9	3.8
22	CTR	Commercial-Transportation	1.9	3.8
23	CMN	Comunication	1.9	3.8
24	TRA	Trade	1.9	3.8
25	FIN	Financial servies	1.9	3.8
26	PUA	Public Administration	1.9	3.8
27	HOR	Hotels & Restaurants	1.9	3.8
28	SER	Other Services	1.9	3.8
29	STR	Self-Transportation	1.9	3.8
	TOT	Total	77.26	157.91

Note: Author calculated base on GTAP Database version 7
ESUBD: Armington CES for domestic/imported allocation
ESUBM: Armington CES for Regional allocation of import

TABLE 6.23: Volume of passenger transport

		Volume of passen- ger carried by re- gion	Volume of passen- ger traffic by region	Volume of passen- gers carried by the road by region	Volume of passen- gers traffic by the road by region
		<i>Mill. Persons</i>	<i>Mill.persons.km</i>	<i>Mill.persons</i>	<i>Mill.person.km</i>
1	NOW	26.8	2,031.9	25.3	2,024.5
2	NOE	6.5	531.7	6.2	528.8
3	RRD	415.3	7,595.2	405.6	7,495.2
4	NCC	43.0	2,676.4	34.8	2,640.1
5	SCC	77.2	3,702.8	74.3	3,686.9
6	CEH	22.6	2,337.4	22.4	2,331.0
7	SOE	297.2	8,839.0	291.6	8,735.9
8	MRD	409.1	12,559.2	293.7	10,107.9
	Total	1,297.7	40,273.6	1,153.9	37,550.3

Note: Author calculated based on Statistical Year Books [103]

TABLE 6.24: Volume of Freight transport

		Volume of freight by region	of freight traffic be region	Distance	Volume of freight by road by region	of freight traffic by road by region	Distance
		<i>Thous.ton</i>	<i>Mill.ton.km</i>	<i>km</i>	<i>Thous.ton</i>	<i>mill.ton.km</i>	<i>km</i>
1	NOW	36,497.7	1,252.5	34.3	33,108.9	1019.1	30.8
2	NOE	5,685.7	323.8	56.9	5,550.7	317.5	57.2
3	RRD	137,567.3	16,235.5	118.0	89,133.4	4,717.0	52.9
4	NCC	51,813.1	2,548.8	49.2	46,333.6	1,578.0	34.1
5	SCC	40,557.0	5,615.3	138.5	38,835.0	3,656.1	94.1
6	CEH	8,820.5	1,058.7	120.0	8,800.9	1,058.5	120.3
7	SOE	71,007.0	11,486.6	161.8	54,579.0	3,858.8	70.7
8	MRD	59,328.2	4,650.9	78.4	18,376.5	1,319.7	71.8
	Total	411,276.5	43,172.1	105.0	294,718.0	17,524.7	59.5

Note: Author calculated based on Statistical Year Books [103]

Chapter 7

Conclusions and Recommendation for Future Works

7.1 A Brief Summary

This chapter aims to summarize the thesis' conclusions and provide recommendations for policy implications. Furthermore, the contributions and limitations of this research also provided and along with the recommendations for further academic research are proposed.

The cores aim of this thesis is to make a comprehensive assessment of transport infrastructure improvements on the economy and identifying new transportation satellite accounts for Vietnam. The brief concluding summarizes are highlighted as follows:

- Chapter 1 introduces the work done in the study. It highlighted the background, aims and objectives, methodology, scope, significant contributions of the research.
- Chapter 2 reviews the trends of global economic integration in recent decades in the world and the impacts of transportation infrastructure development on the economy. The development and applications of CGE modeling in various countries including both developed and developing countries are also considered in this chapter.
- Chapter 3 provides the current situation of transportation investment policy of Vietnam. Existing models using to estimate the economics effects of transportation investment are discovered. Appropriate methodology is suggested for policy-maker in order to estimate the efficiency of transportation infrastructure investment policy for Vietnam's economy also presented in Chapter 3.

- The study conducted in Chapter 4 as follows aggregating Interregional Input-Output data as well as Input-Output data for and developing transportation satellite account as a new database for Vietnam.
- Chapter 5 is to develop a multi-regional CGE model with focuses on the effect of transport infrastructure investment on the economy with consideration of freight transport and passenger flows have been applied in order to estimate the effects of the economic impacts of transport policies. An empirical study was conducted with data of Vietnam is written in Chapter 6.
- Chapter 6 includes two parts. First, a simulation using GTAP model to estimate the economic effects of international transportation improvement on Great Mekong Subregion (GMS). The data used for the simulation derived from GTAP Data base version 7. Second, a preparation of data base for simulation of multiregional CGE model for Vietnam, calibrated to the 2005 interregional input-output which is published in 2009, production and household data, the model is to evaluate the efficiency and distributional effects of transportation improvement.

7.2 Conclusions

As stated above, the cores aim of this thesis is to make a comprehensive assessment of transport infrastructure improvements on the economy and identifying new transportation satellite accounts. The research introduced a multiregional CGE model for Vietnam. It deals with the effects of infrastructure transportation investment in commodities transportation cost of interregional trade and households' welfare effects due to the time and cost saving in passenger transport.

The important novelties of this research are that identifying new transportation satellite accounts for the country's economy, and to endogenous, incorporates travel time with keeping consistency SNA by defining wage rate corresponding to the time, explicitly consider transport sector by keeping consistency of TSA with SNA.

7.3 Recommendations for Future Works

This research examines the topic of transportation infrastructure and economic integration using the multi-regional CGE model with Interregional Input-Output data. The

analysis provides insight into the characteristics of the underlying transportation economic along with the effects of freight transport and passenger flows in term of freight volume and time resources, respectively, from the changes in the transportation infrastructure investment.

It is very positively that, after completing the research, the knowledge of this research will contribute to some extend as follows:

- A transportation data obtained through transportation satellite accounts in chapter 4 is hope to bring in transport economic contributions for researchers, particular for Vietnam and ASEAN member countries.
- A multi-regional CGE model with incorporates travel time is hoped to bring in innovative academic contributions, particularly about the estimation the effects of transportation policy change on freight transport and passenger travel time.
- The empirical studies might be extended to cover not only in Vietnam but also for developing countries in ASEAN economic region.

In spite of every effort to pursue the objectives of this research, there are some limitations of this study. The focus of the study is to investigate the economic effects of transportation infrastructure investment. The other aspects such as social and environmental effects are therefore not within the scope of the study. In addition, the scope of this study concentrate on ASEAN region, the economic effects of international transportation infrastructure investment project would be extended to broader area including other regions in Asia as well as global manner.

The environmental problems that have been emerging rapidly all over the world since the middle of the 20th century are widely believed to constitute major problems to be faced in the 21st century. A growth in carbon emissions from transportation area will inevitably contribute to the deterioration of environment quality in regions. Therefore, additional measures will be required to estimate the effects of reduce emissions from road transport.

A recommend for an extended future research is Strategic environmental assessment (SEA) for transportation infrastructure investment. SEA is an essential tool for effective decision-making in transport policy development and investment planning.

The followings are among the area that could provide potential ideas for future research:

- A multiregional CGE model to estimate the economic effects of global transportation infrastructure improvement.

- Integrated transport CGE model and land-use to contribute to the effectiveness of urban transportation planning policy by estimating the carbon emission impacts.
- Integrated SEA and transport CGE model in order to provide a better decisions for along-term transportation investment planning.

Appendix A

This appendix provides calculation of demand function for the multiregional CGE model that developed and explained in chapter 5.

Industry's behavior

The production technology is illustrated in Fig 5.2. Industry j in region s produce output Q_j^s . Adopted Leontief-type technology for the intermediate goods provided from industry i , x_{ij}^s , and value-added VA_j^s . The input coefficients a_{vj}^s and a_{ij}^s are constant. The output Q_j^s is presented as follows

$$Q_j^s = \min \left[\frac{VA_j^s}{a_{vj}^s}, \frac{x_{ij}^s}{a_{ij}^s} \right] \quad (\text{A.1})$$

Value-added VA_j^s is presented as follows

$$VA_j^s = \left[\sum_{k \in K} \delta_{kj}^s f_{kj}^s \frac{\sigma_2 - 1}{\sigma_2} \right]^{\frac{\sigma_2}{\sigma_2 - 1}} \quad (\text{A.2})$$

Unit cost of value-added as follows

$$uc_{V_j}^s = \min (r f_{1j}^s + w^s f_{1j}^s + p_{zj}^s z_j^s) \quad (\text{A.3})$$

s.t.

$$VA_j^s = \left[\sum_{k \in K} \delta_{kj}^s f_{kj}^s \frac{\sigma_2 - 1}{\sigma_2} \right]^{\frac{\sigma_2}{\sigma_2 - 1}} = 1 \quad (\text{A.4})$$

Solving optimization problem in equation (A.3), (A.4) and using Lagrange multipliers method, we obtain the following input factor and the business trip demand function.

$$f_{kj}^s = \left[\frac{\delta_{kj}^s \omega_k^{s1-\sigma_{2i}}}{\sum_k \delta_{kj}^s \omega_k^{s1-\sigma_{2i}} + \delta_{zj}^s p_{zj}^{s1-\sigma_{2i}}} \right] \left[\frac{ucV_j^s}{\omega_k^s} \right] \quad (\text{A.5})$$

$$z_j^s = \left[\frac{\delta_{zj}^s p_{zj}^{s1-\sigma_{2i}}}{\sum_k \delta_{kj}^s \omega_{zj}^{s1-\sigma_{2i}} + \delta_{zj}^s p_{zj}^{s1-\sigma_{2i}}} \right] \left[\frac{ucV_j^s}{p_{zj}^s} \right] \quad (\text{A.6})$$

Bibliography

- [1] D.A. Aschauer. Is public expenditure productive? *Journal of Monetary Economics*, 23:177–200, 1989.
- [2] Hofmann U. Pfahler, W and W. Bonte. Does extra public infrastructure capital matter? *Finanzarchiv, N.F.*, 53:68–112, 1996.
- [3] K. Spiekermann and M. Wegener. *Socio-economic and spatial impacts of trans european transport networks: the SASI project. World Transport Research. Volume 4: Transport Policy. Selected Proceedings of the 8th WCTR.* Elsevier, Amsterdam, 1999.
- [4] C.K. Liew and C.J. Liew. Measuring the development impact of a proposed transportation systems. *Regional Science and Urban Economics*, 14(2):pp.175–198., 1984.
- [5] J. Brocker. *Assessing spatial economic effects of transport by CGE analysis: State of the art and possible extensions.* Internet: <ftp://ftp.bwl.unikiel.de/pub/ifr/papers/Canada.zip>, 2001.
- [6] Tawai T. Ueda, T. and Y. Hayashiyama. Ex-post evaluation of japanese high-speed transport systems. 1999.
- [7] A.J. Venables and M. Gasiorek. The welfare implications of transport improvements in the presence of market failures. Technical report, SACTRA Working Paper A, 1998.
- [8] Glyn Wittwer Mark Horridge, John Madden. The impact of the 2002-2003 drought on australia. *Journal of Policy Modeling*, 27:285–308, 2005.
- [9] Kobayashi K. Matsushima K. Sharina, F.H. and Xu D. Global infrastructure and optimum production allocation by heterogeneous firms. 2008.
- [10] L. Alan Winters Azita Amjadi and Alexander Yeats. Transport costs and economic integration in the americas. *Swiss Journal of Economics and Statistics*, 131 (3): 465–488, 1995.

-
- [11] R. Roson and P. Vianelli. Developing a multi-regional network cge model for freight transport analysis. In *Paper presented to the NECTAR meeting in Paris*, 1993.
- [12] R. Rohr and I. N. Williams. Modeling the regional economic impacts of the canal tunnel. *Environmental and Planning*, 21, 1994.
- [13] I.N. Williams and G. Lindberg. *Swedish Trunk Road Study: Comprehensive planning system. Report to the National Road Administration, Sweden*. Cambridge, 1989.
- [14] Riley J.; Minford, P.; Stone P. and B. Webb. An economic model of merseyside: Validation and policy simulations. *Regional Studies*, 21:555–567, 1994.
- [15] U.S. Department of Transportation Bureau of Transportation Statistics. Transportation satellite accounts: A new way of measuring transportation services in america. Technical report, BTS99-R-01. Washington, DC:1999, 1999.
- [16] George Modelski. *Principles of World Politics*. New York, Free Press., 1972.
- [17] G. Thompson Hirst Paul, editor. *Globalization in Question*. Cambridge Polity Press, 1996.
- [18] Jagdish Bhagwati. *In Defence of Globalization*. Oxford, New York:Oxford University Press, 2004.
- [19] Romer Paul. Idea gaps and object gaps in economic development. *Journal of Monetary Economics*, 32(3):pp 543?573, 1993.
- [20] Hassan Gholipour Fereidouni Ali Ziaee Khurram Ghani, Yuserrie Zainuddin. Afta: Effect on malaysian economy. *Journal of Management and Social Sciences*, Vol. 4, No. 2,:134–141, (Fall 2008).
- [21] Asean community in figures (acif) 2010. Technical report, Association of Southeast Asian Nations (ASEAN), 2010.
- [22] Biswa Nath Bhattacharyay. Infrastructure development for asean economic integration. Technical report, ADBI Working Paper Series No. 138, May 2009.
- [23] Somchai Ratanakomut Stephen E. Reynolds Danupon Ariyasajjakorn, James P. Gander. Asean fta, distribution of income, and globalization. *Journal of Asian Economics*, doi:10.1016/j.asieco.2009.02.009:9, 2009.

- [24] Dietzenbacher E. & Basu D. Pal, D. P. Economic integration: systemic measures in an input-output framework. *economic systems research. Economic Systems Research*, pages 397–408, 2007.
- [25] Mongsawad P. Sudsawasd, S. Go with the gang, asean! *ASEAN Economic Bulletin*, 24(3):339–356, 2007.
- [26] D. Park. The prospects of the asean-china free trade area (acfta): a qualitative overview. *Journal of the Asia Pacific Economy*, pages 485–503, 2007.
- [27] M. G. Plummer. Best practices in regional trading agreements: An application to asia. *The World Economy*, page 1771?1796, 2007.
- [28] N Birdsall. Underfunded regional in the developing wolrd. working paper no.24. Technical report, Center Global Development, Washington, DC, 2004.
- [29] E. Meersman, H. Van de Voorde. is freight transport growth inevitable. In *ECMT Which Changes for Transport in the Next Century. 14th International Synosium of Theory and Practice. Paris: OECD, pp 23-51*, 1999.
- [30] B. Kulshreshtha, M. Nag. Structure and demand of non-suburban passenger travel demand in india railways. *Transportation*, 27:221–241, 2000.
- [31] Brunel Julien. Freight transport and economic growth: An empirical explanation of the coupling in the eu using panel data. Technical report, Transportation Economics Laboratory (UMR-CNRS 5593), University Lumiere Lyon 2, France, 2005.
- [32] H. Kuroda. Infrastructure and regional cooperation. In *Paper presented at the Bank Conference on Development Economies, Tokyo, Japan. May 29-30.*, 2006.
- [33] World Bank. Empowerment and poverty reduction: The world bankfs agenda. Technical report, World Bank: Washington, DC., 2002.
- [34] United Nation Economics, Social Commission for Asian, and Pacific (UNESCAP). Enhancing regional cooperation in infrastructure development including that related to disaster management. Technical report, New York UN, 2006.
- [35] O Yong. Economic integration and energy cooperation in asean. In *Keynote speech at the 8th Gas Information Exchange (GASEX): Singapore. 01 June. Available: <http://www.aseansec.prg/1639.htm>*, 2004.
- [36] Greater Mekong Subregion. Greater mekong subregion (gms). Technical report, Available: <http://www.adb.org/GMS/Sector-Activities/energy.asp>, 2009.

- [37] World Bank. World development indicators. Technical report, World Bank: Washington, DC., 2008b.
- [38] ICF Consulting. Economic effects of transportation: The freight story final report. Technical report, HLB Decision-Economics, 2002.
- [39] Transportation Research Board. Nchrp report 456, guidebook for assessing the social and economic effects of transportation projects. Technical report, National Cooperative Highway Research Program, National Research Council, 2001.
- [40] Mark Wardman. The value of travel time: A review of british evidence. *Journal of Transport Economics and Policy*, Vol. 32, No. 3:285-316, 1998.
- [41] John Schroeder Mohring, Herbert and Paitoon Wiboonchutikula. The values of waiting time, travel time, and a seat on a bus. *Rand Journal of Economics*, 18, No.1:40-56, 1987.
- [42] L Johansen. *A Multisectoral Study of Economic Growth*. Amsterdam: North-Holland, 1960.
- [43] A. Harberger. The incidence of the corporation income tax. *Journal of Political Economy*, 70 (3):215-40, 1962.
- [44] H. Scarf. *On the Computation of Equilibrium Prices*. Ten Economic Studies in the Tradition of Irving Fischer. New York: Wiley, 1967.
- [45] J. Slemrod. *A General Equilibrium Model of Taxation with Endogenous Financial Behavior*. *Behavioral Simulation Methods in Tax Policy Analysis*. Chicago: University of Chicago Press, 1983.
- [46] J. Bandara. Computable general equilibrium models for development policy analysis in ldc's. *Journal of Economic Surveys*, 5 (1):3-69, 1991.
- [47] M. Burfisher R. Hinojosa-Ojeda Robinson, S. and K. Thierfelder. Agricultural policies and migration in u.s.-mexico free trade area: A computable general equilibrium analysis. *Journal of Policy Modeling*, 15 (5-6):673-701, 1993.
- [48] M. Kokoshi and V. Smith. A general equilibrium analysis of partial-equilibrium welfare measures: The case of climate change. *American Economic Review*, 77 (3):331-41, 1987.
- [49] J. Rollo and A. Smith. The political economy of central european trade with the european community: Why so sensitive? *Economic Policy*, 16:139-81, 1993 (April).

- [50] C. Keuschnigg and W. Kohler. *Eastern Enlargement of the EU: A Dynamic General Equilibrium Perspective. Using Dynamic Computable General Equilibrium Models for Policy Analysis*. Amsterdam: NorthHolland., 2000.
- [51] J.B. Shoven and J. Whalley. *Applying General Equilibrium*. New York: Cambridge University Press., 1992.
- [52] K. J. Arrow and G. Debreu. The existence of an equilibrium for a competitive economy. *Econometrica*, 22:pp. 265–90., 1954.
- [53] J.B. Shoven and J. Whalley. Applied general equilibrium models of taxation and international trade: An introduction and survey. *Journal of Economic Literature*, 23:1007–1051, 1984.
- [54] Peter J. Lloyd and Donald MacLaren. Gains and losses from regional trading agreements: A survey. *Economic Record*, 80, No. 251:445–467, 2004.
- [55] Subhes C. Bhattacharyya. Applied general equilibrium models for energy studies: A survey. *Energy Economics*, 18:145–464, 1996.
- [56] B. Decaluwe and A. Martens. Cge modelling and developing economies: A concise empirical survey of 73 applications to 26 countries. *Journal of Policy Modeling*, 10, No. 4:529–668, 1988.
- [57] Romulo A. Chumacero Klaus Schmidt-Hebbel. General equilibrium models: An overview. Technical report, General Equilibrium Models for the Chilean Economy, edited by Romulo Chumacero and Klaus Schmidt-Hebbel, Santiago, Chile. Central Bank of Chile., 2005.
- [58] R. Baldwin and Venables. *Regional Economic Integration. Handbook of International Economics, Vol. III*. North-Holland, Amsterdam, 1995.
- [59] Liew L. A johansen model for regional analysis. *Regional Science and Urban Economics*, 14:129146, 1984.
- [60] Rimmer R Higgs PJ, Parmenter BR. A hybrid top-down, bottom-up regional computable general equilibrium model. *Int Reg Sci Rev*, 11(3):317–328, 1988.
- [61] Partidge M Morgan W, Mutti J. A regional general equilibrium model of the united states: Tax effects on factor movements and regional production. *Rev Econ Stat*, 71:626–635, 1989.
- [62] Patrick H. Buckley. A transportation-oriented interregional computable general equilibrium model of the united states. *The Annals of Regional Science*, 26:331–348, 1992.

- [63] W. Isard. Interregional and regional inputoutput analysis: A model of a space-economy. *Review of Economics and Statistics*, 33(4):318–28, 1951.
- [64] Djankov S.D.-Stern R.M. Brown D.K., Deardorff A.V. An economic assessment of the integration of czechoslovakia, hungary, and poland into the european union, research seminar in international economics. Technical report, Discussion Paper no. 380, University of Michigan, 1995.
- [65] D. Piazzolo. Polandfs membership in the european union: An analysis with a dynamic computable general equilibrium (cge) model. Technical report, LICOS Discussion Papers, 89. Retrieved from: <http://www.econ.kuleuven.be>, 2000.
- [66] Z.-G; L. Westin L. Friez, T.L; Suo. *Integration of Freight Network and Computable General Equilibrium Models. In Network Infrastructure and the Urban Environment - Advances in Spatial Systems Modeling*. Springer- Verlag, 1998.
- [67] J Brocker. *Spatial Effects of European Transport Policy: A CGE approach. In Trade, Networks and Hierarchies*. Berlin. Springer- Verlag, 2002.
- [68] T. Miyagi. Economic appraisal for multiregional impacts by a large scale expressway project: A spatial computable general equilibrium approach. Technical report, Tinbergen Institute Discussion Paper 2001-066/3 Netherland, 2001.
- [69] Y. Kanemoto and K. Mera. General equilibrium analysis of large transportation improvements. *Regional Science and Urban Economics*, 15:343–363, 1985.
- [70] Makoto Okumura Kiyoshi Kobayashi. The growth of city systems with high-speed railway systems. *Ann Reg Sci*, 31:39–56, (1997).
- [71] S.-I. Mun. Transport network and system of regions. *Journal of Urban Economics*, 42:205–221, 1997.
- [72] Shinya HANAOKA Hajime INAMURA Kazuhiko ISHIGURO, Tomoki ISHIKURA. Development of multi-regional computable general equilibrium model taking account of ocean carriers' behavior and scale economy. *Journal of the Eastern Asia Society for Transportation Studies*, 5, October, 2003.
- [73] Hiroshi Sakamoto. Cge analysis of transportation cost and regional economy: East asia and northern kyushu. In *This paper was presented at an internal seminar of ICSEAD and the 57th Annual North American Meetings of the Regional Science Association International (Denver, USA in 2010)*.
- [74] Kanemi Ban Shiro Takeda. Regional effects of trade liberalization in japan: A cge analysis based on an interregional input-output table. 2010.

- [75] D. Yang. What has caused regional inequality in china? *China Economic Review*, 13:331–334, 2002.
- [76] Zhang X Fan, S. Infrastructure and regional economic development in rural china. *China Economic Review*, 15:203–214, 2004.
- [77] Li K. W Liu, T. Disparity in factor contributions between coastal and inner provinces in post-reform china. *China Economic Review*, 17:449–470, 2006.
- [78] Bo Meng Asao Ando. Transport sector and regional price differentials: A scege model for chinese provinces. Technical report, INSTITUTE OF DEVELOPING ECONOMIES DISCUSSION PAPER No. 81, 2006.
- [79] Zhang Xueliang. Transport infrastructure, spatial spillover and economic growth: Evidence from china. *Front. Econ. China DOI 10.1007/s11459-008-0029-1 Springer-Verlag 2008*, 3(4)::585?597, 2008.
- [80] Glyn WITTWER Mark HORRIDGE. Sinoterm, a multi-regional cge model of china. *China Economic Review*, 19:628–634, 2008.
- [81] A. Kokko. Vietnam: Ready for doi moi ii?,15(3). Technical report, ASEAN Economic Bulletin, 1998.
- [82] A. Fforde. Lighting within the asean gloom? the vietnamese economy since the first asian economic crisis (1997) and in the light of the 2001 downturn. paper for the vietnam updatre 2001: Government of vietnam: The role of organizations. Technical report, Faculty of Arts and Social Sciences, National University of Singapore, 2001.
- [83] L.H. Quy Le Thanh Nghiep. Measuring the impacts of doi moi on vietnam’s gross domestic product. *Asian Economic Journal*, 14:pp. 317–332, 2000.
- [84] Tran Tho Dat. Total factor productivity growth: Survey report-vietnam. Technical report, National Report, APO (Asian Productivity Organization), Tokyo, 2004.
- [85] Bui Trinh Pham Quang Ngoc and Nguyen Duc Thanh. Structural change and economic performance of vietnam 1986-2000: Evidence from the three input-output tables. In *International Input-Output Association*, 2006.
- [86] Duong Manh Hung Kwang Moon Kim Bui Trinh, Mai Quynh Nga. Multi interregional economic impact analysis based on multi-interregional input output model consisting of 7 regions of vietnam, 2000. Technical report, DEPOCEN Working Paper Series No. 2007/12, 2007.

- [87] Duong M. H. Francisco T. S. Bui, T. and Kim K. Compilation of an multi-regional inter-regional input-output framework table for the vietnam's economy. Technical report, DEPOCEN Working Paper Series No. 31, 2008.
- [88] Bui Trinh Vanndy Nor Hung Duong Manh Francisco Secretario, Kim Kwangmoon. Comparative studies of indochina economies (cambodia, thailand and vietnam): An input-output approach. Technical report, DEPOCEN Working Paper Series No. 2009/10, 2009.
- [89] Jeanet ; Huong Thi Lan Abbott, Philip; Bentzen and Finn Tarp. A critical review of studies on the social and economic impacts of vietnam's international economic integration. Technical report, MPRA Paper No. 29789, March 2007.
- [90] M. Ghosh Chan, N. and J. Whalley. Evaluating tax reform in vietnam using general equilibrium methods. Technical report, University of Western Ontario Working Paper 9906., 1999.
- [91] J. de Melo Dervis, K. and S. Robinson. General equilibrium models for development policies. Technical report, World Bank Research Publication, Cambridge University Press: Cambridge, 1985.
- [92] S. Devarajan and J.D. Lewis. Policy lessons from trade focused two-sector models,. *Journal of Policy Modeling*, 12 (4):625–657, 1990.
- [93] J. Piggott and J. Whalley. *UK Tax Policy and Applied General Equilibrium Analysis*. Cambridge University Press: Cambridge., 1985.
- [94] E. Fukase and W. Martin. The effect of the united statesf granting most favored nation status to vietnam. Technical report, World Bank Policy Research Working Paper 2219, 1999a.
- [95] Thomas W. Hertel. *Global Trade Analysis Modeling and Applications*. Cambridge University Press, 1997.
- [96] A. Elbehri McDougall, R. A. and T. P. Truong. Global trade assistance and protection: The gtap 4 data base,. Technical report, Center for Global Trade Analysis, Purdue University: https://www.gtap.agecon.purdue.edu/databases/archives/v4/v4_dco.asp, 1998.
- [97] E. Fukase and W. Martin. A quantitative evaluation of vietnamfs accession to the asean free trade area,. Technical report, World Bank Policy Research Working Paper 2220., 1999b.

- [98] D. Puga and A. J. Venables. Agglomeration and economic development: Import substitution vs. trade liberalization,. Technical report, Centre for Economic Performance Discussion Paper 377. <http://diegopuga.org/papers/dp0377.pdf>, (1998).
- [99] N. Chan and T. K. Dung. Development of a cge model to evaluate tariff policy in vietnam,. In *Paper presented at International Conference on Policy Modelling, Free University of Brussels, July 4-6, 2002.*, (2001).
- [100] James A. Giesecke Tran Hoang Nhi. Growth and structural change in the vietnamese economy 1996-2003: A cge analysis. Technical report, The Center of Policy Studies (COPS), Monash University, 2008.
- [101] Nguyen Duc Thanh. Economywide effects of international remittances: A computable general equilibrium assessment for vietnam. Technical report, Centre for Economic and Policy Research, College of Economics, Vietnam National University, Ha Noi, 2008.
- [102] Haas R. Hudson, W.R. and W. Uddin. *Infrastructure Management: Integrating Design, Construction, Maintenance, Rehabilitation, and Renovation*. McGraw-Hill, New York, 1997.
- [103] GSO. Statistical yearbook of vietnam 2007, 2008, 2009 hanoi,. Technical report, General Statistical Office of Vietnam, 2009.
- [104] Ministry of Transport. Vietnam's transport development orientation for the next decades. Technical report, Ministry of Transport, <http://www.mt.gov.vn>, 2004.
- [105] MOT. The transport development strategy of vietnam up to 2020. Technical report, Ministry of Transport., 2007.
- [106] Hisaaki Mitsui. Impacts assessment of large scale transport infrastructure in northern vietnam. Technical report, Japan Bank for International Cooperation, 2004.
- [107] Fumi Idei Shozo Sakata Tran Van Tho, Akifumi Kuchiki. Impact assessment of transport infrastructure projects in the northern vietnam. Technical report, 2003.
- [108] Hanoi AusAIDS, Australian Agency for International Development. My thuan bridge impact monitoring study. In *Presentation at workshop on Development of Large Scale Infrastructure for Growth and Poverty Reduction*, 2003.
- [109] Vu Thieu and Janaiah Aldas. Poverty impacts of public irrigation spending in vietnam. Technical report, Manuscript in preparation, Hanoi, 2003.
- [110] Trinh Quang Long Fan Shenggen, Pham Lan Huong. Government spending and poverty reduction in vietnam. Technical report, Report prepared for the World Bank funded

- project Pro-poor spending in Vietnam, International Food Policy Research Institute and Central Institute of Economic Management, Hanoi, 2004.
- [111] Pham Lan Huong Rama Larsen. The impact of infrastructure development on rural poverty reduction in Vietnam. In *A case study from Reducing Poverty Sustaining Growth. What Works, What Doesn't, and Why: A Global Exchange for Scaling Up Poverty Reduction Success: A Global Learning Process and Conference Shanghai May 25-27, 2004*.
- [112] Prime Minister. Socio economic development strategy and the comprehensive poverty reduction and growth strategy (cprgs). Technical report, The Socialist Republic of Vietnam, Approved at Document No. 2685/VPCP-QHQT, 2003.
- [113] W Leontief. Quantitative input and output relations in the economic system of the United States. *Review of Economics and Statistics, Cambridge, MA, Harvard University Press.*, 18 (3):105–25, 1936.
- [114] W Leontief. *Input-Output Economics*. New York, Oxford University Press., 1966.
- [115] Richard Stone. *Input-Output and National Accounts*. OEEC, Paris, 1961.
- [116] K. Miyazawa. Internal and external matrix multipliers in the input-output model. *Hitotsubashi Journal of Economics*, 7:pp. 38–55, 1966.
- [117] Francisco T. S. Kim K. Bui, T. and M. H. Duong. Construction of an inter-regional input-output table for Vietnam by the hybrid approach: The case of Ho Chi Minh City and the rest of Vietnam. In *The 15th International Conference on Input-Output Techniques, Beijing China, 2005*.
- [118] Department of Business. The Hawaii inter-county input-output study: 2002 benchmark report. Technical report, Economic Development and Tourism State Of Hawaii, March 2007.
- [119] K. Miyazawa. An analysis of the interdependence between service and goods producing sectors. *Hitotsubashi Journal of Economics*, 12:pp. 10–21, 1971.
- [120] K. Miyazawa. *Input-Output Analysis and the Structure of Income Distribution*. Heidelberg. Springer-Verlag., 1976.
- [121] H. W. Richardson. *Input-Output and Regional Economics*. London, 1972. .
- [122] E. Kolleritsch Fritz O. and G. Streicher. Building a multiregional input-output table for Austria: Compilation methods and results. In *Paper presented at the Intermediate Input-Output Conference on Sustainability, Trade and Productivity, 26-28 July, Sendai, Japan.*, 2006.

- [123] C. L. Verduras. The estimation of the interregional trade in the context of an interregional input-output model for the spanish economy. available: <http://www.iioa.org/pdf/13the.pdf>. In *Paper presented at the 13th International Conference on Input-Output Techniques, 21-25 August, University of Macerata, Italy.*, 2000.
- [124] Y. Ishikawa and T. Miyagi. The construction of a 47-region inter-regional input-output table and inter-regional interdependence analysis at prefecture level in japan. In *Paper presented at the 44th European Congress of the European Regional Science Association, Porto, Portugal. Available: <http://www.ersa.org/ersaconfs/ersa04/PDF/432.pdf>*, 2004.
- [125] Okamoto N.; Y. X. Zhang; S. Hioki; T. Kanazawa and K. Zhao. A method for constructing an interregional input-output model of china for 2000. *Journal of Econometric Study of Northeast Asia, Available: <http://www.erina.or.jp/en/Publications/jesna/pdf/jesna5-2.pdf>*, 5(2):23–6, 2005.
- [126] K. Kim Secretario F. and C. Goce-Dakila. The metro-manila inter-regional inputoutput table: Its attempt of compilation by the hybrid approach. In *Paper presented at the 14th International Conference on Input-Output Techniques, 10-15 October, Montreal, Canada. Available: <http://www.iioa.org/pdf/14thconf/kimkwangmoon.pdf>*, 2002.
- [127] Secretario F. T. B. Trinh D. M. Hung and K. M. Kim. Construction of an inter-regional input-output table for viet nam by the hybrid approach. In *Paper presented at the Symposium on Study on Regional Economic-Natural Environment in Viet Namfs Transition Economy, 1 July Nissan Research Foundation Hanoi*, 2003a.
- [128] Jari Kauppila. Transport satellite accounts: Recent development. Technical report, Joint Transport Research Centre of the OECD and the International Transport Forum, 2010.
- [129] John Sutton Peter B. Dixon, B. R. Parmenter and D. P. Vincent. *Orani: A Multisectoral Model Of The Australian Economy*. North-Holland Publishing Company Amsterdam . New York . Oxford, 1982.
- [130] Mitsuhiro Miyashita Atsushi Koike, Takayuki Ueda. Scge model for passenger transport improvement. *In Japanese*, 17:237–245, 2000.
- [131] S. Stone and A. Strutt. Transport infrastructure and trade facilitation in the greater mekong subregion. Technical report, ADBI Working Paper Series No. 130, 2009.
- [132] GSO. Vietnam household living standards survey 2006, 2008. Technical report, Ministry of Planning and Investment, 2006,2008.

- [133] S. Wahba Chia, Ngee-Choon and J. Whalley. A general equilibrium based social policy model for cote- d'ivoire. Technical report, Working papers WPS 925, The World Bank, 1992.

Vu Trung Dien

Email address: wru.info@gmail.com

Url: <http://vuson.vn/vu>

Home address in Vietnam:

So nha 12 Ngo 19 Pho Vuong Thua Vu

Hanoi - Vietnam

Tel: +84 (0)43 5656 183

Mobile: +84 098-890 2333